

# ESBE SERIES ARA600 3-Point

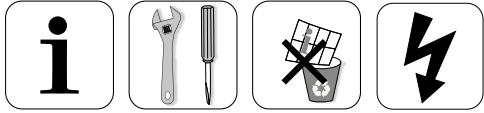

Series ARA6x1  
Series ARA6x2  
Series ARA6x3  
Series ARA6x4

CE

LVD 2014/35/EU  
EMC 2014/30/EU  
RoHS 2011/65/EU

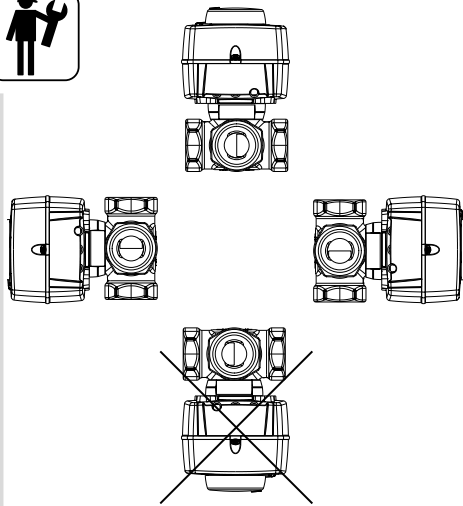
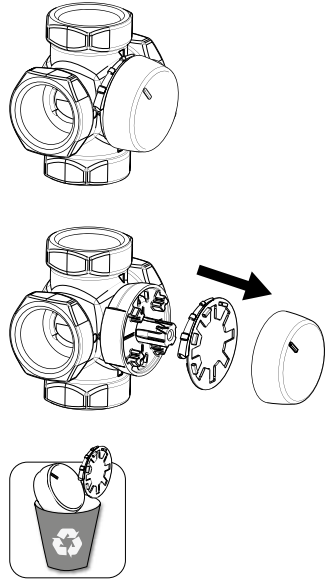
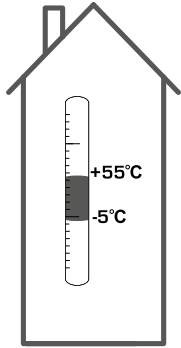

## Series MG, G, F, H, HG, BIV, T, TM

	DN15-25	
	DN20-40	
	DN50	
	DN20-25	
	DN32-50	
	H: DN25	
	H: DN32-50	
	HG: DN25	
	DN20-22	
	DN25	
	T: DN20-32	
	TM: DN20	

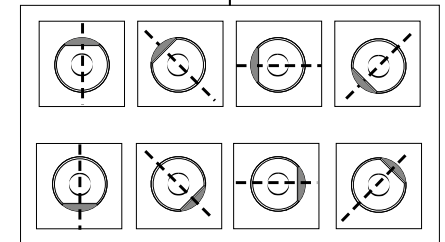
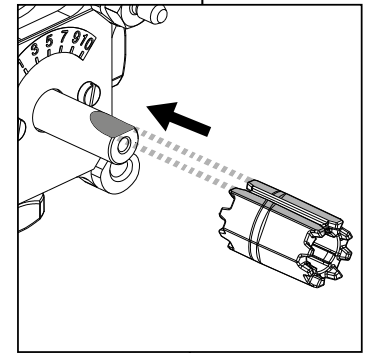
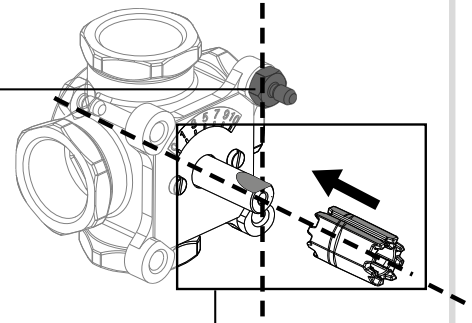

VRG, VRB, VRH

3MG, 4MG



3G, 4G

3F, 4F ≤ DN50

3HG, 4HG, 3H, 4H



BIV

T, TM

Series VRGxxx, VRBxxx, VRHxxx

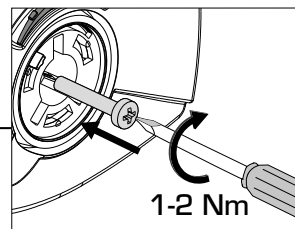
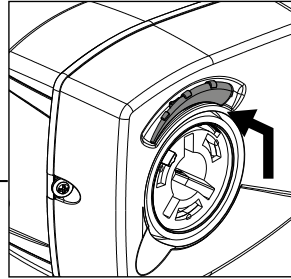
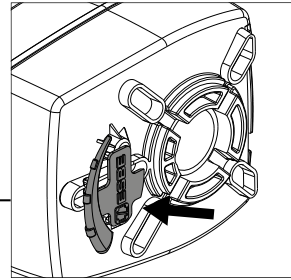
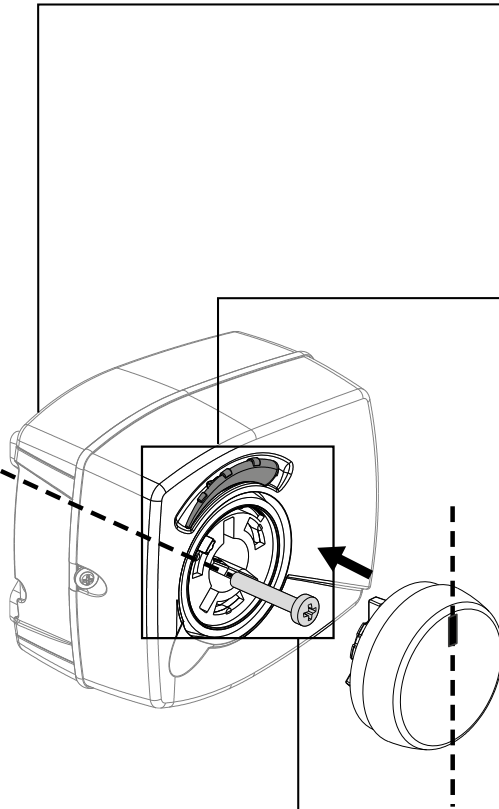
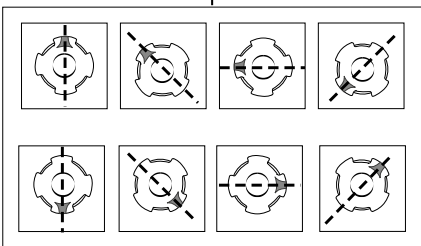
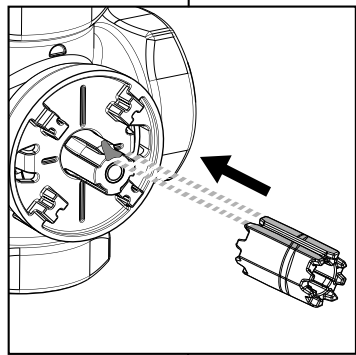
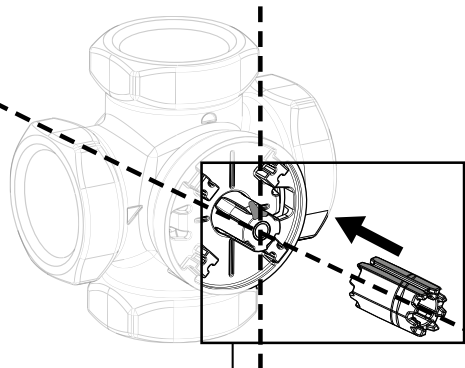

Mtrl.nr: 9814 02 75 • Ritr.nr: 8081 utg. H • Rev. 1607



**SERIES ARA600 3-Point**



**NO.1 IN HYDRONIC SYSTEM CONTROL**

**SERIES VRG130**

**a**

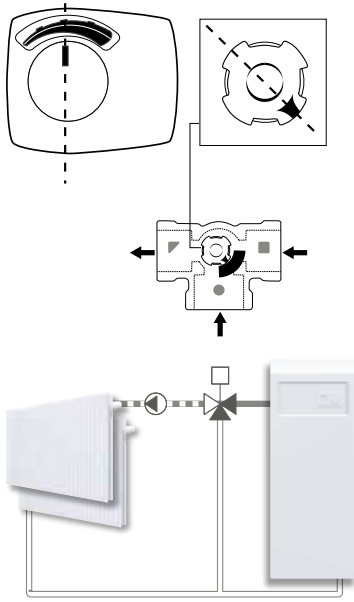

**b**

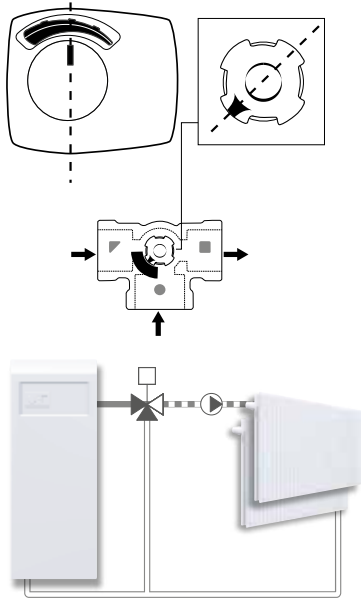

**c**

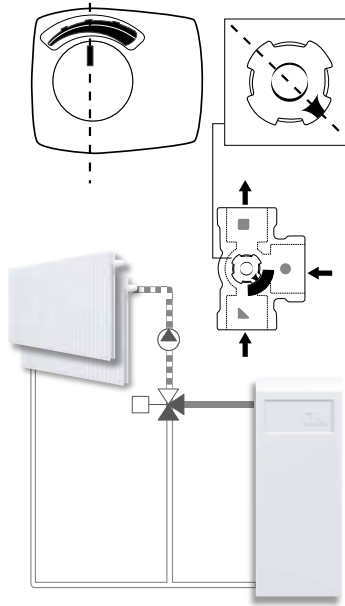

**d**

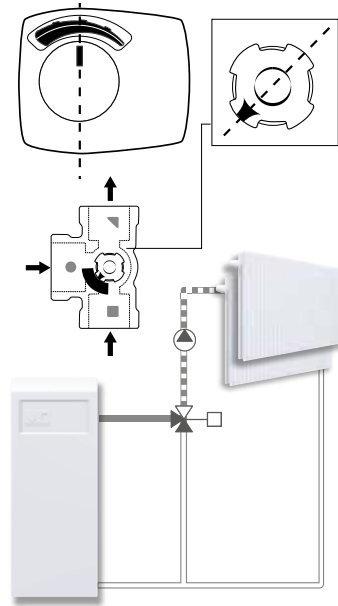

**e**

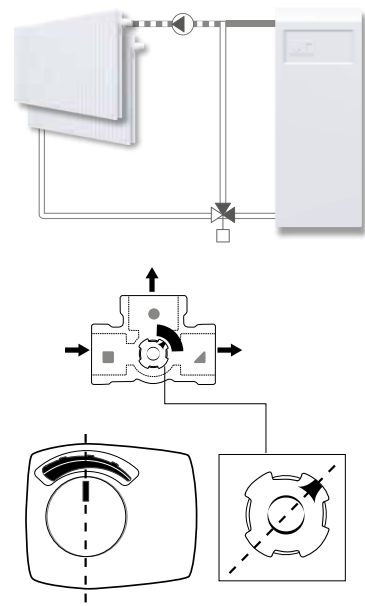

**j**

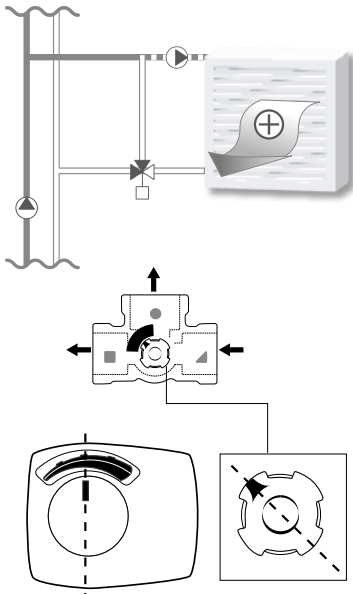

**k**

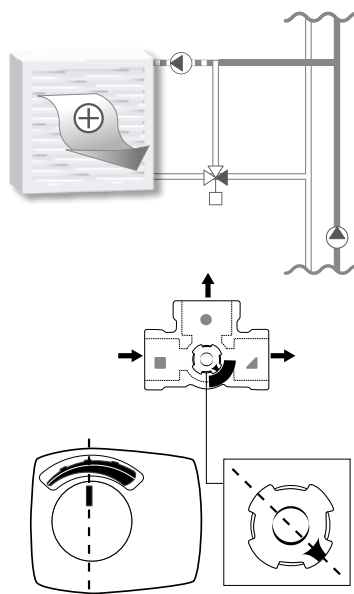

**l**

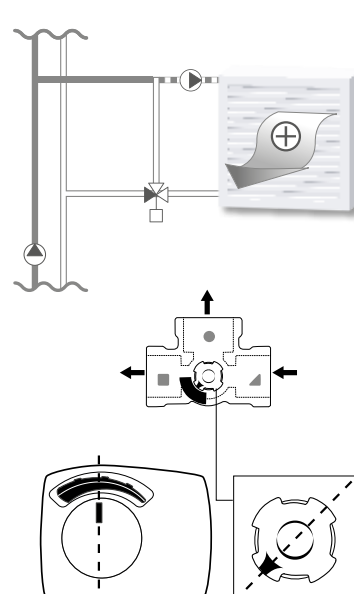

**m**

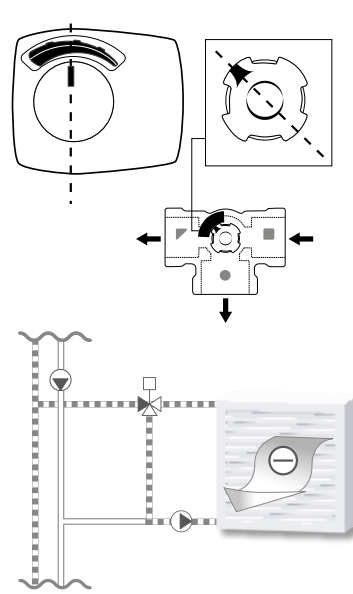

**n**

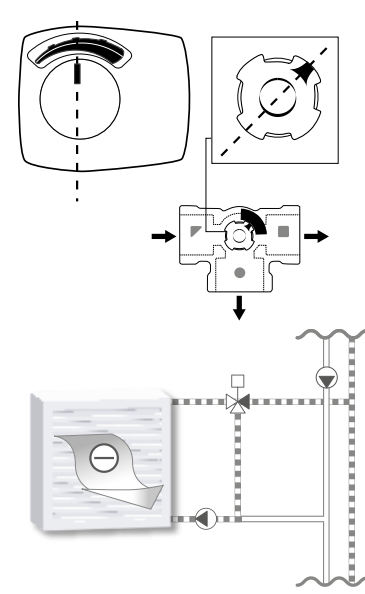

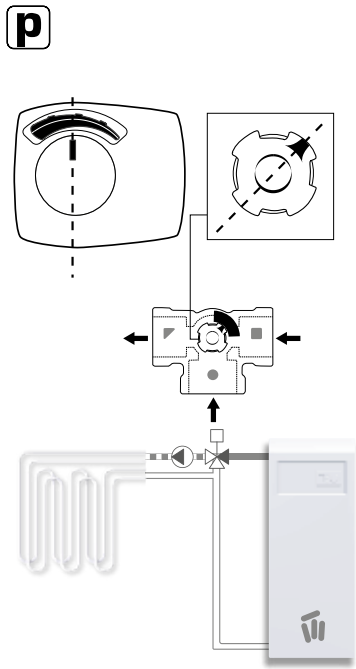
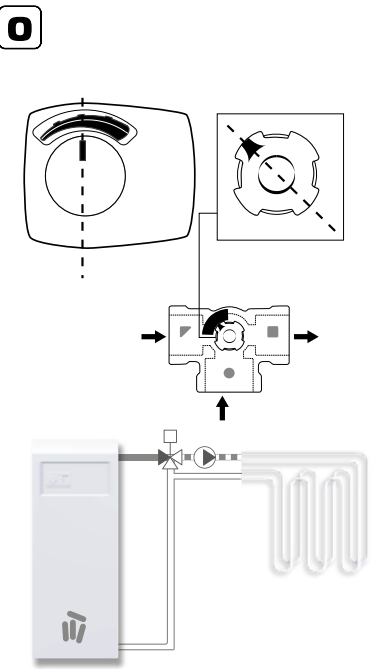
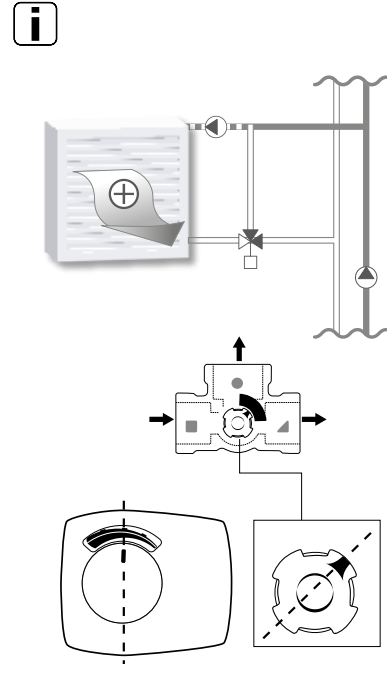
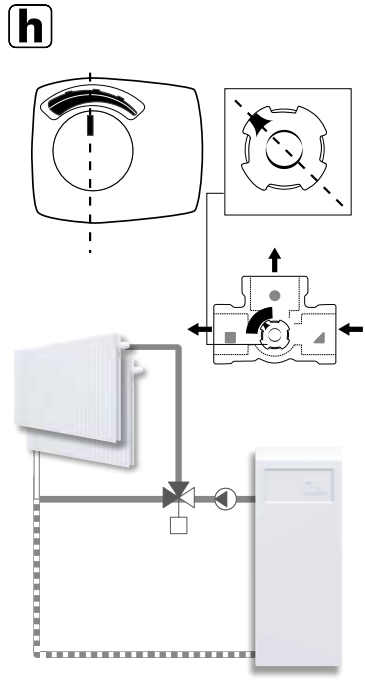
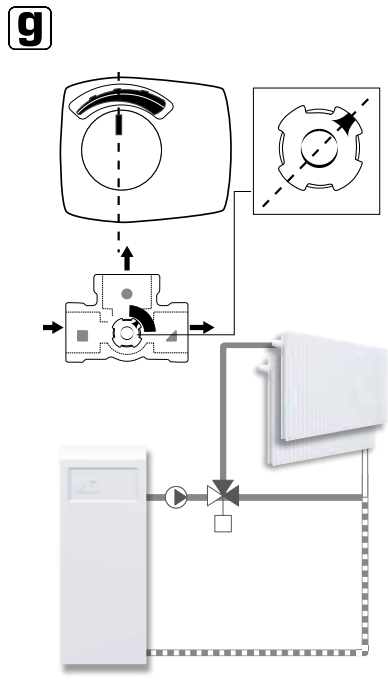
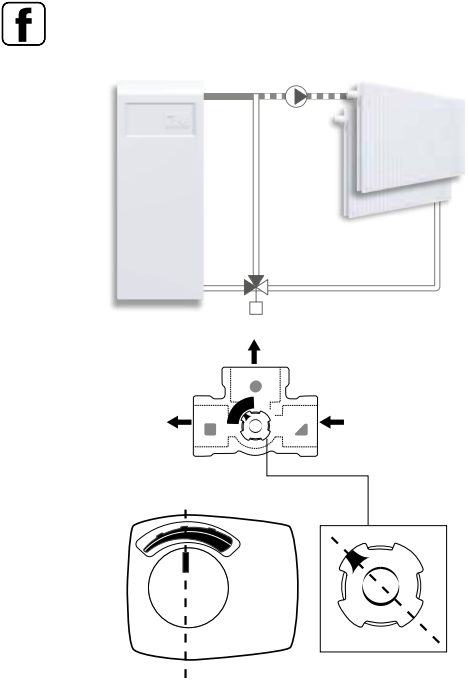

**SERIES VRG140**

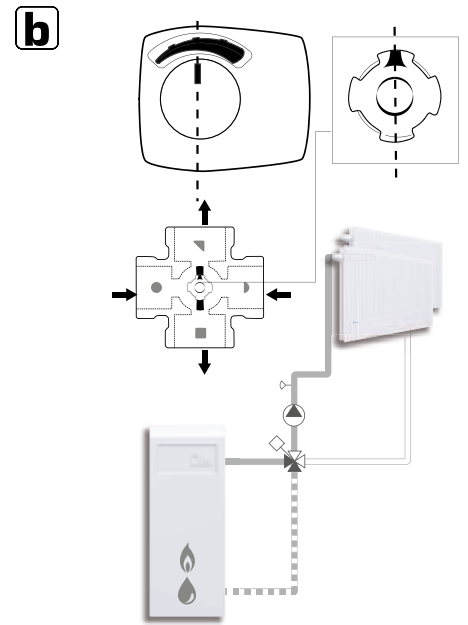
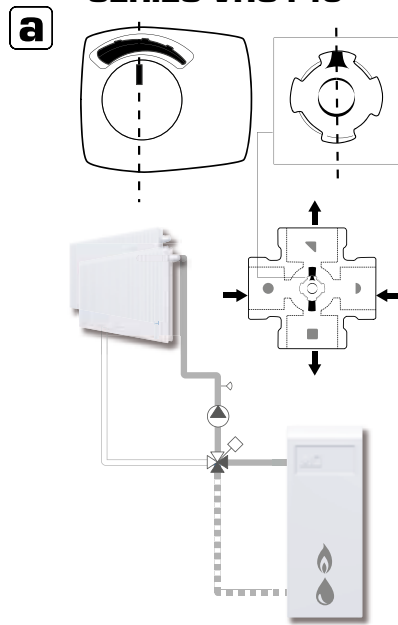

### SERIES VRG230

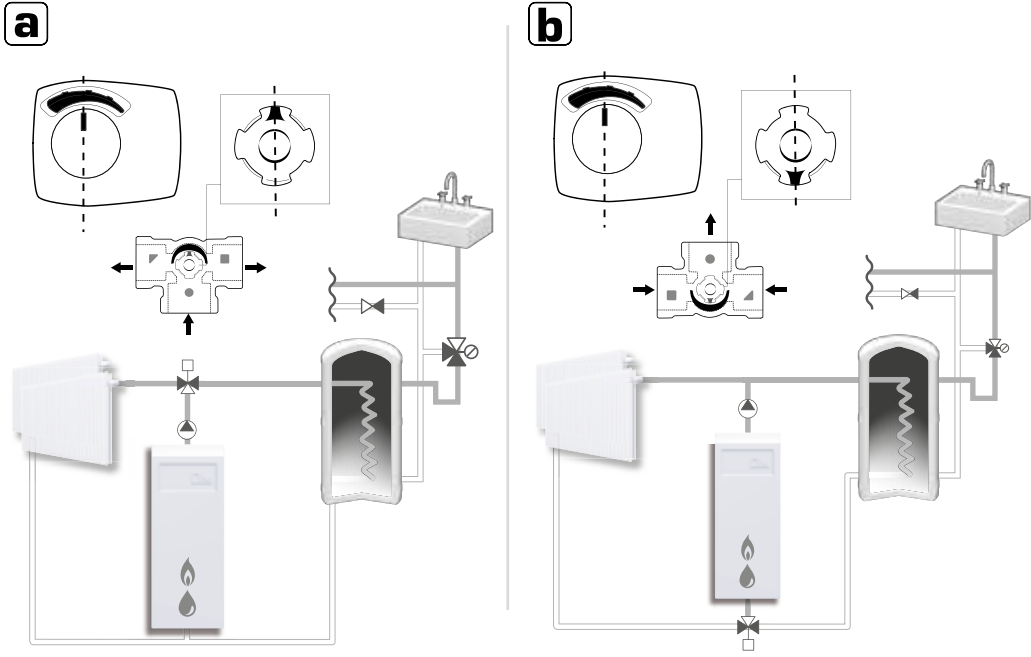

### SERIES VRH130

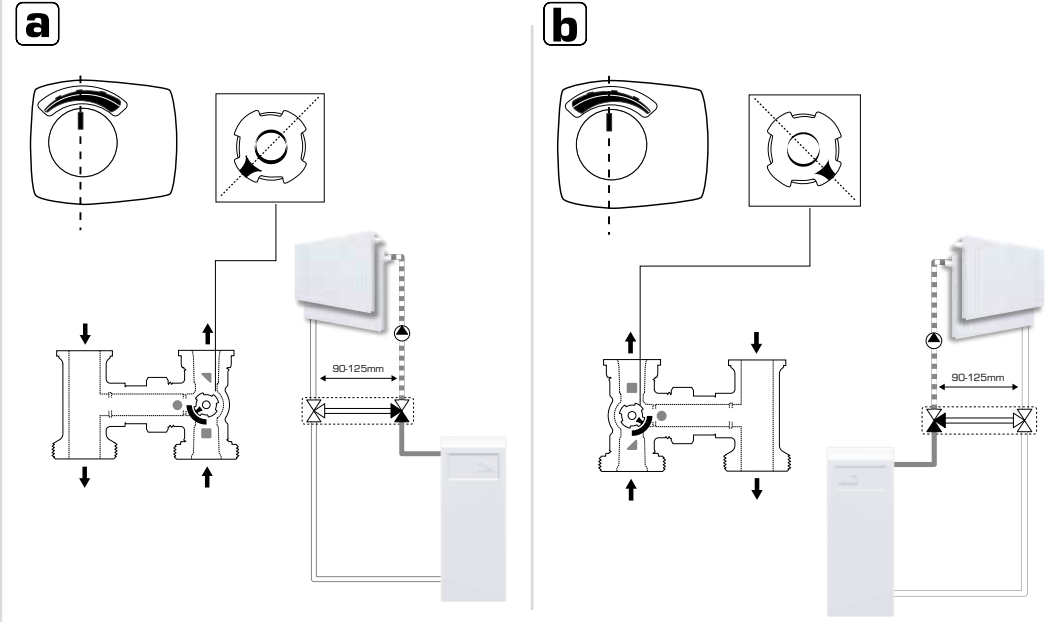

### SERIES VRG330

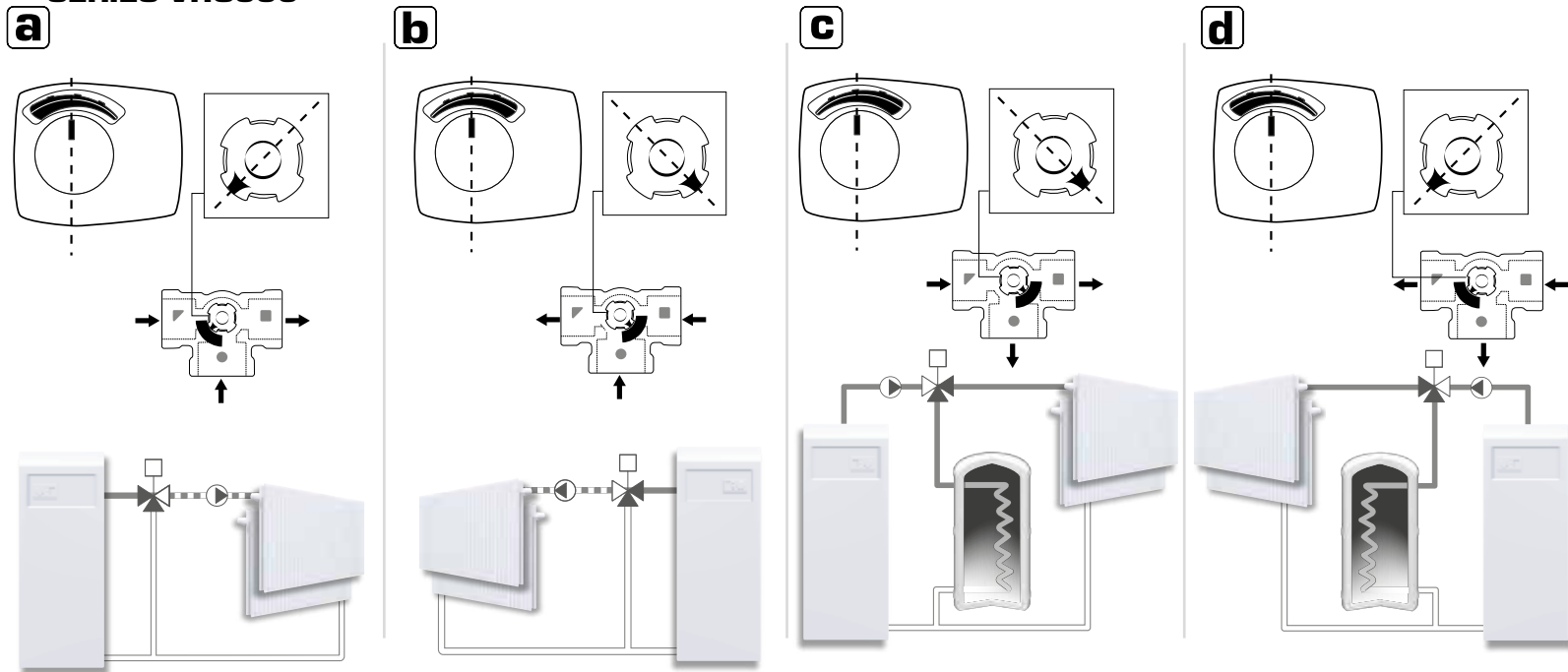

# SERIES VRB140

**a**

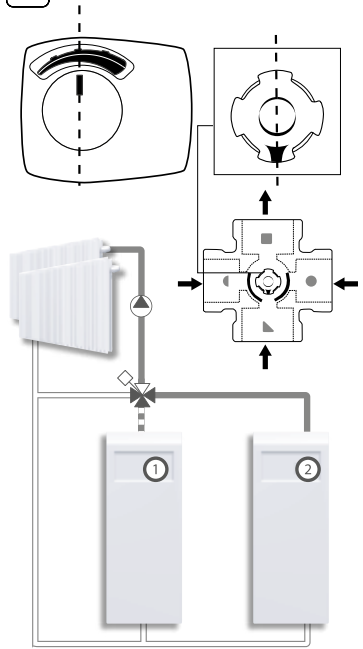

**b**

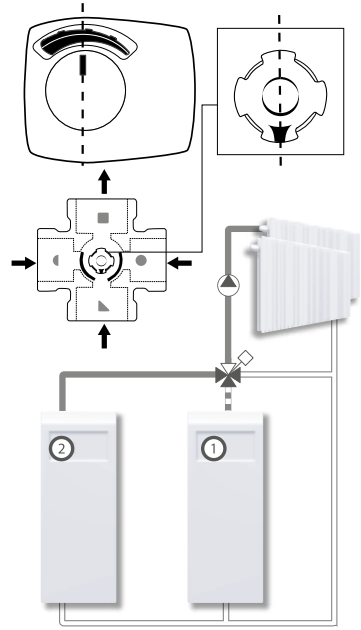

**c**

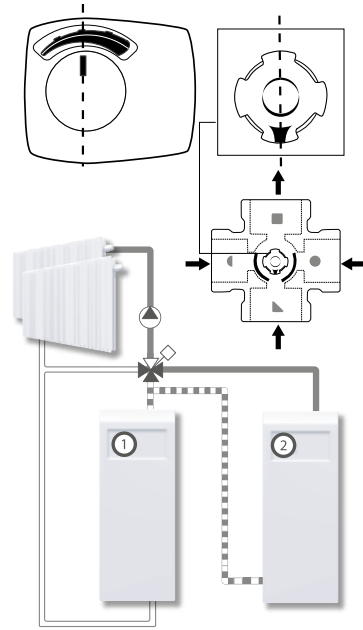

**d**

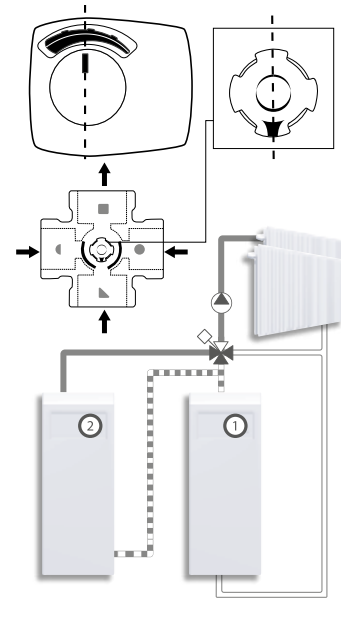

**e**

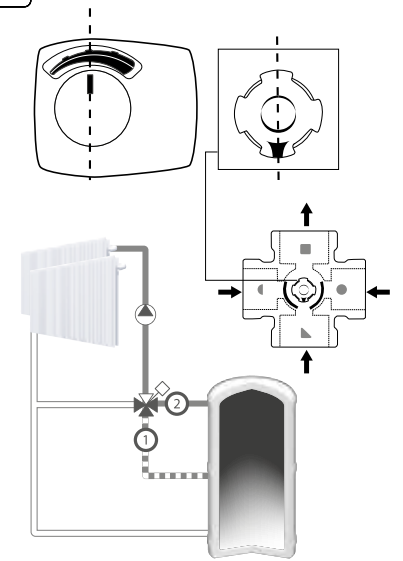

**f**

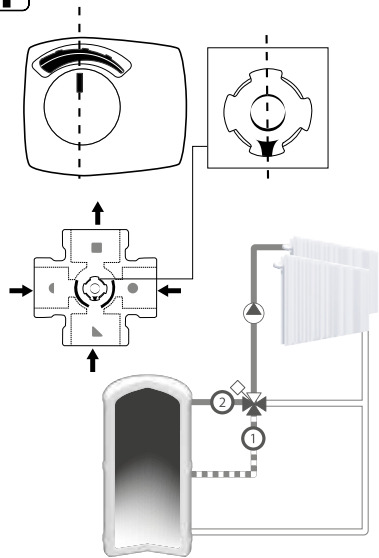

**g**

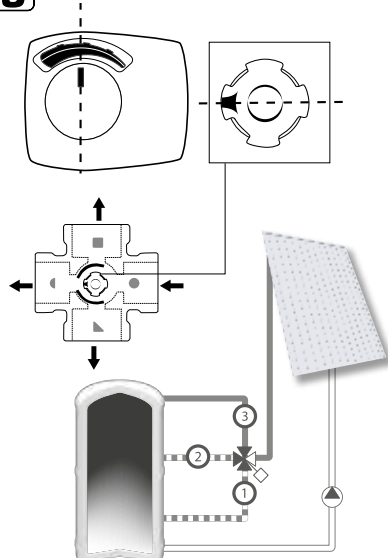

**h**

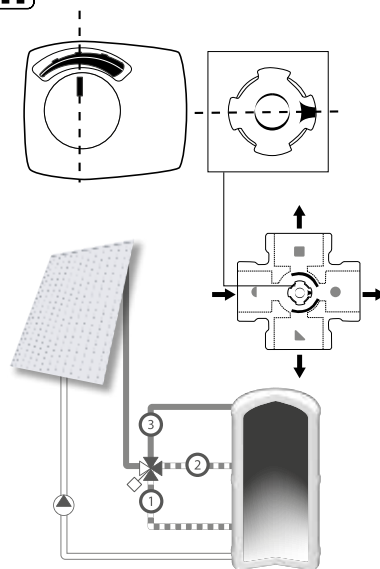

*"We would like to pinpoint to the existence of a German patent DE 19821256C5 affecting the usage of bivalent 4-way valves in liquid circulation heating systems. In this patent the usage of a 4-way bivalent valve in a type of heating system is protected, in which 2 different heating circuits are operated in parallel, where the return of the first circuit is utilized as heat source for the parallel second heat circuit. A typical application would be a primary heat circuit with a heat source and a parallel floor heating, where the floor heating in a regulated manner is heated through its heat source and the return from the primary heat circuit is utilized as alternative secondary heat source for the floor heating. Such a utilization of our bivalent 4-way valve without approval of the patent holder is forbidden. All other applications our product group VRB are without restrictions possible."*



### Series ARA6x1, ARA6x3

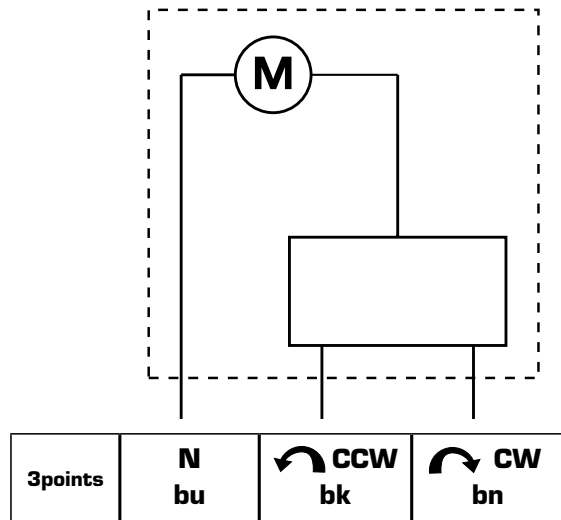

### Series ARA6x2, ARA6x4

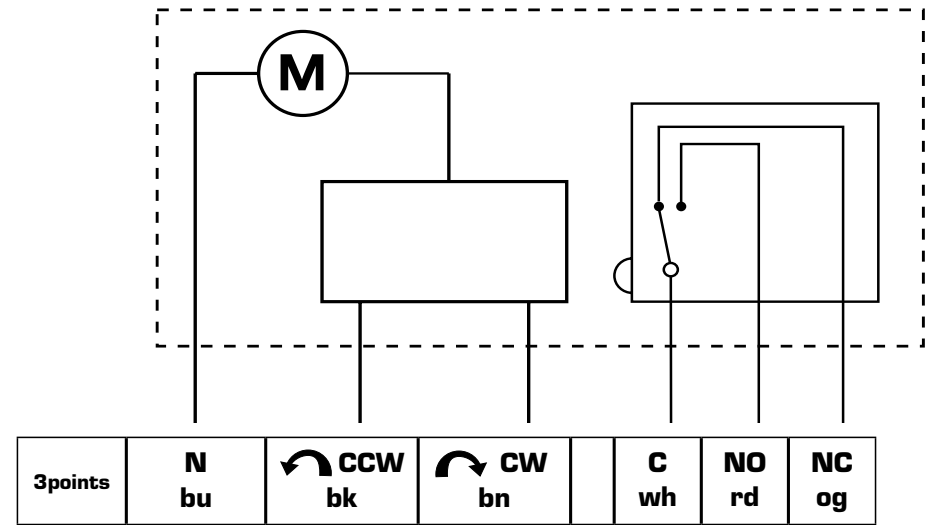

### Series ARA6x2, 6x4

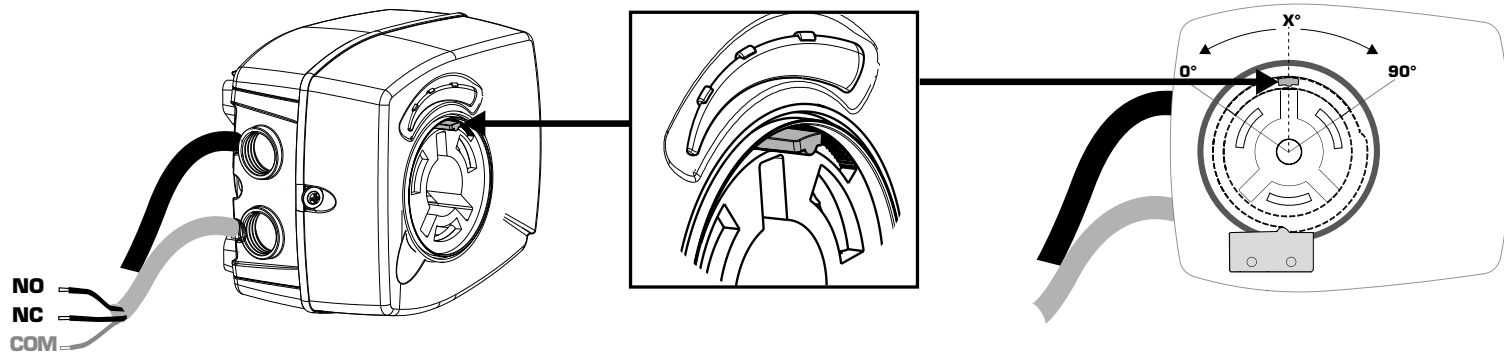

	0° - (90° - x°)	(90° - x°) - 90°
NO		
NC		
	X° = 45°	

Series ARA69x



1



2

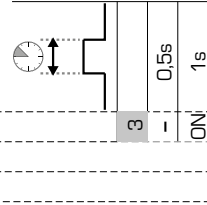
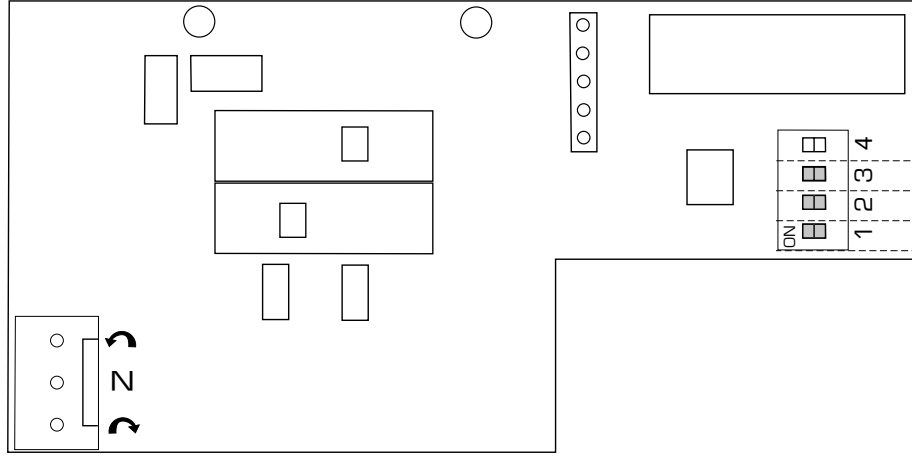
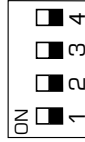
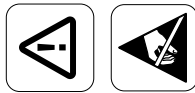
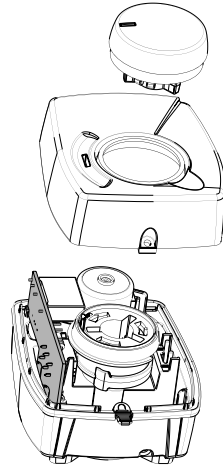
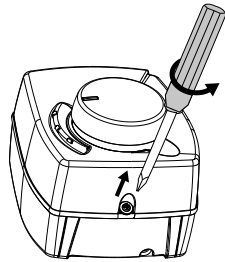

1	2		
-	-	120s	
-	ON	240s	
ON	-	480s	
ON	ON	1200s	

