



METAL ELEMENTS AND BOILER MANUFACTURER

28-100 Busko-Zdrój, Owczary, ul. Przemysłowa 3

Phone: +48 41 378 46 19, Fax +48 41 370 83 10

TECHNICAL DOCUMENTATION OF
WATER CENTRAL HEATING BOILER OF
SAS AGRO-ECO TYPE

SAS
AGRO-ECO



INDEX

Conformity Declaration	3-4
Ecological Certificate	5
1. Introduction	6
2. Boiler destination	6
3. Boiler construction description	7
4. Technical and operation parameters	10
Boiler construction scheme	11-12
5. Fuel	13
6. Guidelines for boiler installation	14
6.1 Requirements for boiler-room	15
6.2 Boiler installation	15
6.3 Chimney connecting	16
6.4 Central heating system connecting	17
6.5 Electrical system connecting	18
7. Guidelines for operating and maintenance	18
7.1 Filling with water	18
7.2 Boiler fire-up and operation	19
7.2.1 Firing up and functioning of a boiler in automatic mode	19
7.2.2 Firing up and functioning of a boiler in emergency mode	21
7.3 Boiler cleaning	21
7.4 Operation ending	22
8. Safe operation conditions	22
9. Troubleshooting	23
10. Protections	24
11. Delivery conditions	25
12. Boiler utilization	25
13. Terms of warranty	26
Service repairs	28
Warranty card	29



Zakład Metalowo – Kotlarski
Mieczysław Sas
ul. Przemysłowa 3, Owczary, 28-100 Busko-Zdrój
tel. + 48 41/378 46 19

SAS AGRO-ECO WB /2009/DZ01

Busko-Zdrój, 07 September 2009

DECLARATION OF CONFORMITY

Document conducted according to Module A
No: S-M/2008

Producer:

Zakład Metalowo – Kotlarski
Mieczysław Sas
ul. Przemysłowa 3, Owczary
28-100 Busko-Zdrój

herewith declares under sole responsibility that the product:

**AUTOMATIC CENTRAL HEATING WATER BOILER
TYPE „SAS AGRO-ECO” BIOMASS POWERED (pellet, sulphur grain)**

of output within the range of 17– 50kW

is in conformity with the requirements
of EC directives:

Directive 98/37/EC

Directive 73/23/EEC

Directive 89/336/EEC

and standards:

EN 12809

EN 303-5

Above-mentioned statement confirms a sign



placed on product

The energetic and efficiency research were conducted by Institute for Chemical Processing of Coal (IChPW) Zabrze Poland and having certificate of accreditation issued by Polish Centre for Accreditation (certificate No: AB081)

ZAKŁAD METALOWO KOTLARSKI

MIECZYSLAW SAS
Owczary, ul. Przemysłowa 3
28-100 Busko-Zdrój
tel. (041) 378 46 19, fax (041) 370 83 10
NIP 655-000-29-64 REGON 008149629
Company stamp

Zakład Metalowo-Kotlarski

Mieczysław Sas
WŁAŚCICIEL

Owner: Mieczysław Sas



Zakład Metalowo – Kotlewski
Mieczysław Sas
ul. Przemysłowa 3, Owczary, 28-100 Busko-Zdrój
tel. + 48 41/378 46 19

SAS AGRO-ECO /2009/DZ01

Busko-Zdrój, 07 September 2009

DECLARATION OF CONFORMITY

Document conducted according to Module A
No: S-M/2008

Producer:

Zakład Metalowo – Kotlewski
Mieczysław Sas
ul. Przemysłowa 3, Owczary
28-100 Busko-Zdrój

herewith declares under sole responsibility that the product:

**AUTOMATIC CENTRAL HEATING WATER BOILER
TYPE „SAS AGRO-ECO” BIOMASS POWERED (pellet, sulphur grain)**

of output within the range of 50– 100kW

is in conformity with the requirements
of EC directives:

Directive 98/37/EC

Directive 73/23/EEC

Directive 89/336/EEC

and standards:

EN 303-5

Above-mentioned statement confirms a sign



placed on product

The energetic and efficiency research were conducted by Institute for Chemical Processing of Coal (IChPW) Zabrze Poland and having certificate of accreditation issued by Polish Centre for Accreditation (certificate No: AB081)

ZAKŁAD METALOWO KOTLARSKI

MIECZYŚLAW SAS
Owczary, ul. Przemysłowa 3
28-100 Busko-Zdrój
tel. (041) 378 46 19 fax (041) 370 83 10
NIP 855-000-29-64 REGON 008149629

Company stamp

Zakład Metalowo-Kotlewski

Mieczysław Sas
WŁAŚCICIEL

Owner: Mieczysław Sas

ECOLOGICAL BOILER FOR SOLID FUELS
CLASS „A”

Certificate no 934
Customer: ZAKŁAD METALOWO-KOTLARSKI „SAS”
28-100 Busko-Zdrój, Owczary, ul. Przemysłowa 3

Construction: Heating boiler with automatic fuel feeding system

Type of boiler: „SAS AGRO-ECO” output range 15 ÷ 100 kW

Fuel: Biomass (pellets)

Boiler energy and emission characteristic (tested output range)

	Parameter	Unit	Achieved values	Criteria
THERMAL EFFICIENCY	Relative thermal load (with respect to nominal output)	%	100±8	-
	Boiler energy efficiency	%	87,7 ÷ 88,8	≥ 80
EMISSION INDICES	CO	mg/m ³	255 ÷ 580	≤ 1200
	NO ₂	mg/m ³	210 ÷ 245	≤ 400
	Dust	mg/m ³	50 ÷ 75	≤ 125
	TOCs	mg/m ³	55 ÷ 60	≤ 75
	16 PAHs acc. to EPA inc. B(a)P	mg/m ³ µg/m ³	0,1 ÷ 0,2 2,1 ÷ 14,6	≤ 5 ≤ 75

FINAL STATEMENT:

Tested boilers fulfill IChPW criteria for „ecological safety sign” for solid fuels boilers in class „A”

Energy and emission indices were elaborated acc. to standard PN-EN 303-5:2002 chapter 5.7-5.10 and technical procedures of IChPW Laboratory of Combustion no. Q/ZS/P/15/01/B and Q/ZS/P/15/02/B

Certificate loses its validity in case of changes in the production phase which can have influence on emission indices or boiler energy efficiency.

DIRECTOR OF CIT

Jarosław Zuwała PhD

DIRECTOR OF INSTITUTE

Marek Ściążko PhD

 Date of issue
07.09.2009 r.

INSTITUTE FOR CHEMICAL PROCESSING OF COAL

Zamkowa 1 str., 41-803 Zabrze; phone. (32) 271 00 41; fax (32) 271 08 09; web: www.ichpw.zabrze.pl

GROUP OF ICHPW LABORATORIES
CERTIFICATE of ACCREDITATION PCA No AB 081
 in range of energy and emission testing of solid fuels and boilers

AB 081

Certificate of testing for „ecological safety sign”



1. INTRODUCTION

Dear purchaser and user of SAS AGRO-ECO boiler. This User Manual contains all information required for ensuring of energy saving, safe and long operation of purchased boiler.

Please read this Manual carefully before boiler installation and running.

2. BOILER DESTINATION

SAS AGRO-ECO boilers equipped with fuel storage bin and automatic feeder are destined for central heating installations working in **open system*** with gravitational or forced water circulation. Installation must be protected in accordance with PN-91/B-02413 standard. Boilers are recommended for single houses, trade service and gastronomic pavilions, workshops, etc, on which heat distribution network water temperature is not higher than 90°C and working pressure is not higher than 0.15 Mpa. Depending on boiler power, required combustion gas draught after boiler is equal 15÷45 Pa.

Boiler can be also connected to hot water installation using heat exchanger.

The basis of selection of boiler for building should be heat balance prepared in accordance with valid PN-B-02025:2001 standard. Boilers of SAS AGRO-ECO type installed in accordance with this documentation are not subject for Office of Technical Inspection acceptance.

* Heating system installation must meet requirements of PN-91/B-02413 and BN-71/8864-27 polish standards regarding protection of water heating devices working in open system and collect water bin of open system.

3. BOILER CONSTRUCTION DESCRIPTION

SAS AGRO-ECO type boiler is a low – temperature boiler for central heating. Boiler is adapted for highly – efficient, fully automatic combustion of biomass supplied as granulated product (called also „pellets”) and grains. Basic elements of boiler are showed on the illustration.

Boiler frame is made from welded steel sheets. The water jacket is in form of cuboid with double walls and separating water baffles. Combustion chamber is mounted under highly efficient convectional heat exchanger.

The unit’s framework based on the three-way convective channel structure makes the most of exhaust heat to heat the water. Upper part of combustion chamber is covered by water jacket.

Combustion gases are carrying away to chimney by smoke conduit (pos 15), located upper part of boiler.

Cleanout hole door, fuel loading door and double door, used as a furnace and ash box door are located on the boiler front side. Front cleanout hole door (pos 2) and fuel loading door (pos 3) enable access to combustion chamber in order to carry out a maintenance activities and boiler convectional ducts periodical cleaning. Door can also be used for manual (emergency) fire-up of boiler in automatic fuel loading mode and is used as a fuel loading door for fuel loading in “conventional” mode. Ash box door (pos 4) is used as a furnace and ashtray door. In ashtray door bottom part flap (pos 5) is located. Flap is used for air intake dosage for combusting process. Lateral cleanout hole door (pos 7) allows removing ash produced during combusting process.

Hot water connector pipe (pos 14) is welded to the heat exchanger upper side. Return water connector pipe (pos 18) is located on the lateral, bottom side of heat exchanger. Blowdown connection (pos 19) is also located on the boiler lateral wall.

Charging hopper (fuel storage bin – pos 13), feeder drive mechanism (pos 10) and downcast ventilator (pos 8) are located on the boiler rear side.

Heat exchanger is covered with insulating material (mineral wool) which filling space between heat exchanger and boiler enclosure.

Characteristic feature of SAS AGRO-ECO type boilers is automatic, highly – efficient, self – cleaning furnace, combusting only fuel portion necessary to reach



temperature defined by user on the temperature controller. Furnace elements exposed to high temperature are made from heat – resisting steel and ceramic materials. Applying of ceramic panels in furnace construction allows to ensure optimal conditions for biomass combustion (corn combustion optimal temperature is equal 1200°C), increasing furnace efficiency and furnace life – time.

Fuel is loading automatically from storage bin through feeding screw. All processes leading to fuel combusting with air supplied by downcast ventilator located under burner enclosure (pos 8) takes place on the combustion chamber fire grate. Blowed air is distributed in air chamber. Primary air is delivered under fire grate; overfire air is blowed into combustion zone through the nozzles system, located in ceramics panels. Depending on fuel applied, electronics circuit controls air volume delivered by downcast ventilator

In order to ensure comfortable operation boiler is equipped with incandescent spiral used for self-acting fuel ignition. Thanks to automatic fuel ignition and fire maintaining system after reaching of defined temperature boiler can operate even if demand for thermal power is very small. Boiler can be operated continuously and is adopted for co-operation with hot water storage bin used in summer time.

Controller with build – in microprocessor automatically controls feeding screw, downcast ventilator, incandescent spiral and furnace cleaning mechanism operation.

Small, non-combustible portion of fuel (ash) remaining after biomass combustion in last combustion stage is carry away to ash box chamber and stored on the removable ash tray (pos 6). Ashtray should be cleaned periodically. Ash reminder from biomass combustion process can be successfully used as a full value, ecological fertilizer for soil refining.

=====

Efficient boiler furnace allows to combust only fuel portion, which is necessary to maintain temperature set by user on the temperature controller. Controller measures constantly water temperature in boiler and based on the results controls the boiler working elements operation. Controller operates also circulating pump of central heating



and hot water storage bin.* Boiler controller is also adopted for operation with any controller of room temperature.

The advantage of boiler operation is simple servicing which requiring only refueling of storage bin (charging hopper must be refueled once per 1-3 days, depending on weather conditions and building thermal insulation) and ash removing from ashtray. There is no need to damp a fire. After light-up, boiler not requiring constant servicing and can operate continuously within whole heating period except periodical, scheduled maintenance activities. Boiler can also operate with hot water storage bin beyond heating season.

Thanks to fuel feeder driven by gear – motor, self-cleaning furnace and electronics temperature controller operation of SAS AGRO-ECO type boiler is operated automatically (continuous operation).

Boiler is adopted for operation in “emergency burning” mode which is very useful in case of no power or feeder / ventilator failure. In this mode boiler operates using natural gas draught and electric energy is not required. Combustion process can be adjusted manually using inflow air adjusting screw mounted in air dosing flap (pos 5).

In order to ensure operation safety, SAS AGRO-ECO boiler is equipped with multi-level protection system. Boiler is protected against flame back to storage bin through fuel feeder (fuel duct temperature sensor) and boiler overheating (thermo breaker). In case of fuel feeder blocking, movable grate-bar driving mechanism damage or flame decay in heating chamber boiler will be switched-off automatically.

In case of power supply cutting, current operation state and all controller settings are stored in memory and thanks to that after power – on boiler is started automatically and defined temperature is reached.

* You will find a detailed description of structure, operation and service of the controller in an enclosed specifications sheet „CONTROLLER OPERATING MANUAL”.

TECHNICAL AND OPERATION PARAMETERS

No.	Parameter	Unit	SAS AGRO-ECO												
1.	Boiler power	kW	17	23	29	36	42	48	58	68	78	90	100		
2.	Boiler heated surface	m ²	1.5	2.0	2.5	3.0	3.5	4.0	5.0	6.0	7.0	8.0	9.0		
3.	Boiler efficiency	%	87,7 ÷ 88,8												
4.	Fuel consumption*	kg/h	1,9	2,6	3,3	4,1	4,8	5,5	6,6	7,2	8,3	9,6	10,7		
5.	Load chamber capacity	dm ³ kg	120 ~75 ÷ 85	120 ~75 ÷ 85	140 ~90 ÷ 100	180 ~115 ÷ 130	210 ~135 ÷ 150	230 ~145 ÷ 165	280 ~180 ÷ 200	320 ~200 ÷ 240	360 ~240 ÷ 260	380 ~260 ÷ 280	410 ~280 ÷ 310		
6.	Boiler water capacity	l	90	100	120	140	160	190	260	350	420	510	620		
7.	Boiler weight (without water)	kg	440	490	520	610	650	780	890	930	1100	1220	1310		
8.	Required chimney draught	mbar	0,30						0,45	0,55					
9.	Exhaust temperature	°C	90 ÷ 210												
10.	Maximal allowable operating pressure	bar	1,5												
11.	Maximal allowable working temp.	°C	85												
12.	Reccomended heating water working temp.	°C	60 ÷ 80												
13.	Minimal return water temp.**	°C	55												
14.	Power supply	V/Hz	~230 / 50												
15.	Power consumption	W	190 (+ 900 at start burning)		210 (+ 900 at start burning)			260 (+ 900 at start burning)		360 (+ 900 at start burning)					
16.	Dimensions	A	mm	1490	1590	1590	1660	1780	1850	1900	1990	2090	2190	2240	
		A1	mm	840	940	940	1020	1020	1090	1140	1180	1180	1280	1280	
		B	mm	550	550	620	620	670	670	740	740	740	780	780	780
		B1	mm	450	450	520	520	570	570	640	640	640	680	680	680
		H	mm	1590	1590	1630	1630	1630	1630	1630	1630	1740	1810	1810	1920
		H1	mm	1420	1420	1420	1440	1520	1540	1540	1540	1610	1610+c*	1610+c*	1720+c*
		C	mm	260	360	360	430	430	450	500	500	500	500	590	590
		C1	mm	180	180	180	180	180	180	250	250	250	250	280	280
	D	mm	520	520	520	520	620	620	620	620	650	650	650	650	
17.	Smoke conduit diameter	mm	Ø160	Ø180	Ø200	Ø200	Ø220	Ø220	Ø250	Ø 260	Ø 270	Ø 280	Ø 300		
18.	Connector pipe diameter(supply/return)	"	G 1½			G 2			G 2½						
19.	Min. chimney height	m	6	7	8		9		10		11		12		
20.	Min. chimney dimensions / diameter	cm x cm mm	18x18 Ø210	20x20 Ø220	21x21 Ø240	22x22 Ø250	25x25 Ø280	25x25 Ø280	26x26 Ø320	26x26 Ø320	28x28 Ø360	28x28 Ø360	29x29 Ø380		

* when working at average load (50% or rated power)/ rated load

**if manufacturer recommendations regarding heating water temperature ranges are not observed, boiler must be obligatory connected to central heating system equipped with tree- or four- ways valve, protecting against so called "low temperatures corrosion"

C* handle use to transport a boiler (dimension 150 mm)

BOILER CONSTRUCTION SCHEME OF SAS AGRO-ECO TYPE (17 - 58 kW)

- | | | | |
|---------------------------|----------------------------|---------------------------------|--|
| 1. boiler cover (body) | 7. lateral washout hole | 13. fuel storage bin | 19. blowdown connection |
| 2. washout door | 8. blowing fan | 14. hot water connector pipe | 20. air regulator knob |
| 3. fuel load door | 9. grate drive mechanism | 15. smoke conduit | 21. exhaust temperature sensor |
| 4. ash box door | 10. feeder drive mechanism | 16. safety valve | 22. handles grate assembly replacement |
| 5. air intake dosage flap | 11. ceramic heater | 17. controller (panel) | 23. connecting strip |
| 6. ash box | 12. ceramic panels | 18. return water connector pipe | 24. air draft regulator |

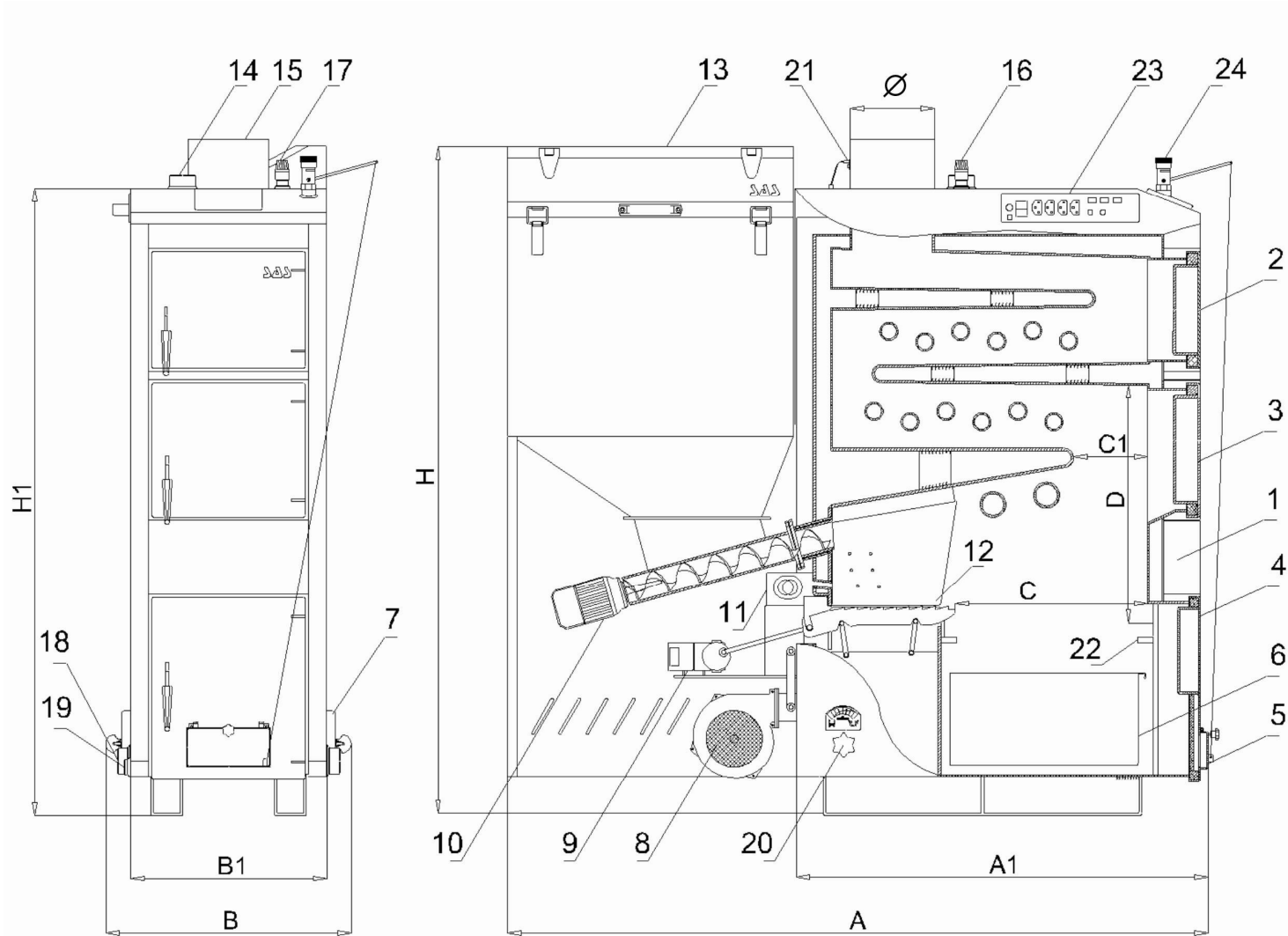

BOILER CONSTRUCTION SCHEME OF SAS AGRO-ECO TYPE (58-100 kW)

- | | | | |
|---------------------------------------|--------------------------------|---------------------------------|---------------------------|
| 1. air intake dosage flap | 7. fuel load door | 13. hot water connector pipe | 19. ceramic heater |
| 2. ash box door | 8. washout door | 14. controller | 20. grate drive mechanism |
| 3. ash box | 9. safety valve | 15. return water connector pipe | 21. blowing fan |
| 4. boiler cover (body) | 10. smoke conduit | 16. lateral washout hole | 22. air regulator knob |
| 5. handles grate assembly replacement | 11. exhaust temperature sensor | 17. blowdown connection | |
| 6. ceramic panels | 12. fuel storage bin | 18. feeder drive mechanism | |

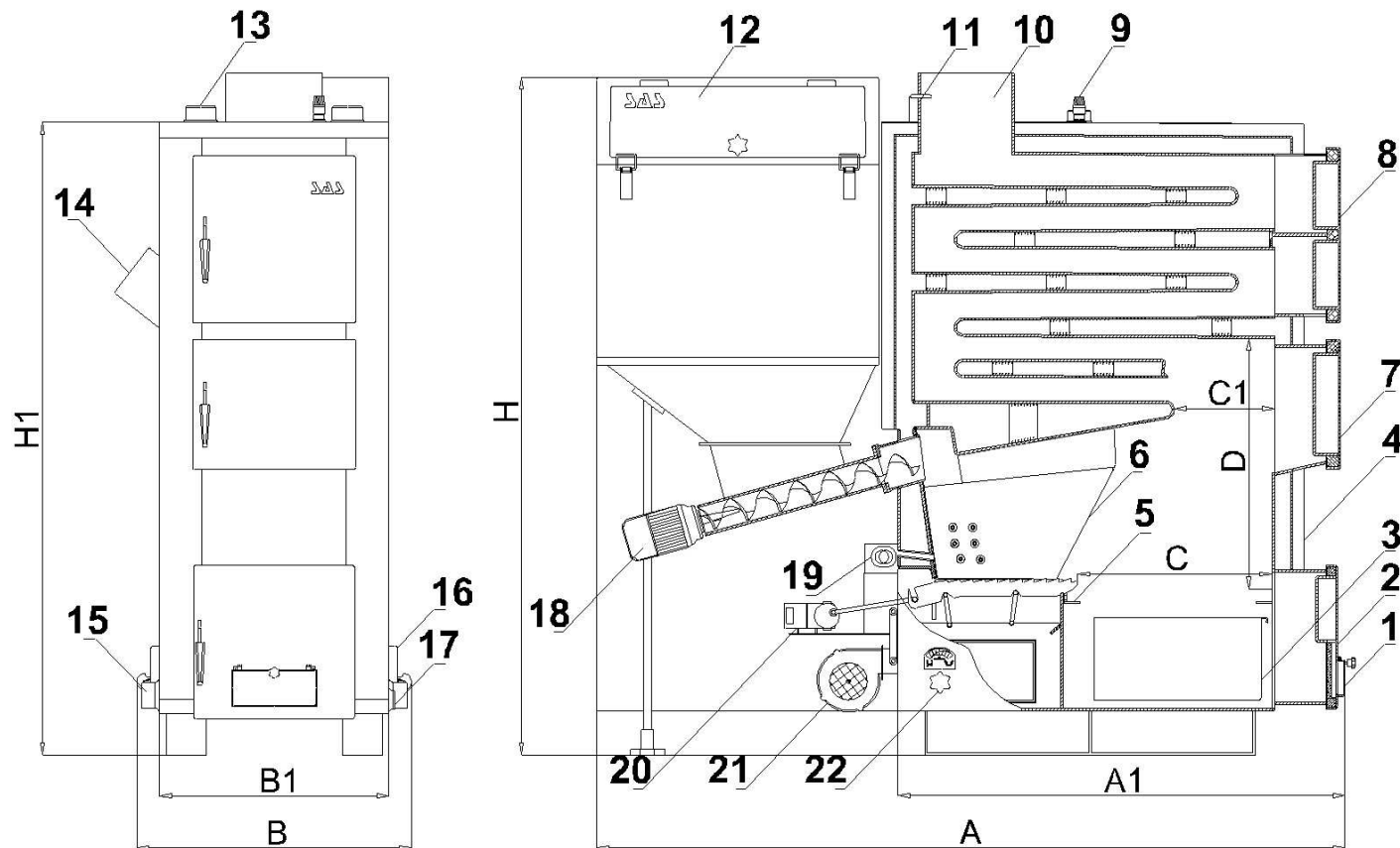

5. FUEL

Problem-free operation of SAS AGRO-ECO type boiler equipped with automatic burner and fuel feeder depends on adequate fuel applying or adaptation of boiler operation to available fuel.

Proper selection of kind of biomass guarantees not only fuel saving (thanks to effective fuel combustion) but also makes possible to save time required for boiler servicing. Kind of bio fuel and also applied bio fuel humidity are very important parameters, which must be taken into account to reach adequate boiler heating results.

SAS AGRO-ECO type boilers combusting miscellaneous fuels – e.g. vegetable products, what gives many possibilities for user. Primary fuel is granulated wood – so called pellets* (both, from sawdust, tree bark, energetic willow and e.g. rape straw). As a secondary fuel – combusted with good results – various grains can be applied, e.g. oat, rye, barley, wheat, charlock, maize, lupine. Other fuels as e.g. willow chips (less than 20 mm of length and less than 15% of humidity), dry stones (e.g. from cherry, etc.) are also allowed. Low quality grains (e.g. from plantations located on polluted areas or from trees with bacteriosis) can also be applied as a fuel. Because furnace is equipped with movable fire-bars mechanism, fuels producing residues can be applied.

OTHER COMBUSTIBLE MATERIALS ARE NOT ALLOWED FOR USE WITHOUT WRITTEN PERMISSION FROM MANUFACTURER.

* Diameter: 6÷8 mm, length 20÷30 mm. Please do not apply fuel with granulation other than stated because it can cause feeder operation problems. In particular, during fuel loading or refueling it is mandatory to check if some unwanted objects or stones are not present. Presence of this kind of objects may cause locking of feeder mechanism.

Basic parameters of granulated product (pellets) for SAS AGRO-ECO type boilers:

Table 2

Granulated product diameter	$\varnothing = 6 \div 8 \text{ mm}$
Granulated product length	$10 \div 30 \text{ mm}$
Calorific value	$16\,000 \div 19\,500 \text{ kJ/kg}$
Humidity	$8 \div 10 \%$
Ash percentage	$0,6 \div 1,0 \%$
Sulphur percentage	$< 0,1 \%$
Specific gravity	$0,65 \div 0,75 \text{ kg/dm}^3$

ATTENTION: Storage bin should be filled with water-free fuel, without excessive quantity of small fraction or foreign matter!

6. GUIDELINES FOR BOILER INSTALLATION

Boiler installation must be realized by qualified staff holding authorization for this kind of activity (specialized person, trained for this kind of activity, holding authorization for maintenance and repair works). Fitter is obligated to become familiar with product, product operation and protection circuits operation manner. Before boiler connecting to central heating system it is mandatory to become familiar with this documentation.

6.1. REQUIREMENTS FOR BOILER-ROOM

Boiler room where central heating system boiler will be installed must meet requirements of currently valid detailed regulations of destination country (e.g. PN-87/B-02411 for Poland).

- boiler-room must be located as centrally as possible in relation to heated rooms, boiler should be installed very close to chimney;
- boiler-room entry door should be opened outwards and must be made from non-flammable materials;
- boiler-room should be equipped with supply ventilation in form of ventilating duct with section not smaller than 50% of chimney section, but not smaller than 21 x 21 cm; outlet must be localized at the rear side of boiler-room. Absence of supply ventilation or ventilation choke may cause smoking or impossibility to reach higher temperature.
- boiler-room should be equipped with exhaust ventilation, located under room floor. Section of duct must not be smaller than 25% of chimney section, but not smaller than 14 x 14 cm. Exhaust ventilation is destined for removing of harmful gases from boiler-room).

ATTENTION:

It is not allowed to apply mechanical exhaust ventilation. Day and artificial lighting should be available.

6.2. BOILER INSTALLATION

A special foundation is not required for boiler installation. It is recommended to install boiler on the 2 cm height concrete footpace, but installation directly on the fire-resisting floor is also allowed. Boiler must be located on such way, which makes possible easy

and safe furnace servicing, fuel loading and boiler cleaning. Very important point is to keep suitable distance (**min. 0,6 m**) between boiler rear side and boiler-room wall.

6.3. CHIMNEY CONNECTING

Chimney duct construction and boiler connecting to chimney must meet requirements of currently valid detailed regulations of destination country (e.g. Decree of Infrastructure Minister dated April 12, 2002, Government bulletin number 75).

Boiler must be connected directly to chimney using smoke flue in form of wrought pipe (allowable temperature of pipe must be higher than 400°C). Pipe diameter must makes possible realization of tight connection between pipe and smoke conduit outlet. Smoke conduit and chimney connection place must be sealed very carefully.

Height and section of chimney and realization precision are key factors for proper boiler operation and because of that they should ensure maintaining of required chimney draught.

Calculating of chimney height and section for boiler power should be realized according to requirements of currently valid detailed regulations of destination country.

Table of chimney height and section recommended by manufacturer in relation to boiler power.

If there is no possibility to ensure recommended chimney parameters and problems with chimney draught appearing (incorrect boiler operation) it is recommended to install waste gases exhaust ventilator or chimney cowl with built-in ventilator, which helps to reach proper draught and draught stabilization.

Because waste gases from boiler should have reflection possibility, chimney must be constructed from boiler-room floor level. Cleanout hole with hermetic closing should be installed on the chimney bottom side.

In order to avoid reverse draught, chimney duct must be minimum 1,5 meter higher than roof ridge. Chimney operation correctness should be checked and confirmed by authorized chimney - sweep minimum once per year.

BEFORE BOILER START-UP CHIMNEY SHOULD BE BURNED !

It is strongly recommended to apply chimney insert made from stainless steel. **In case of long-lasting low temperature keeping in boiler applying of chimney insert**

is mandatory. Keeping the low temperature in boiler causing emission of wet waste gases. It can be a reason of moisture and corrosion of chimneys made from brick.

**CHIMNEY OPERATION CORRECTNESS SHOULD BE
CONFIRMED BY AUTHORIZED CHIMNEY SWEEP.**

6.4. CENTRAL HEATING SYSTEM CONNECTING

Boiler should be connected with central heating system using screw joints. Protection of heating installations working in open system should be realized according to requirements of currently valid detailed regulations of destination country (e.g. PN-91/B-02413 for Poland). Volume of collect water bin should be equal minimum 4% of volume of water flowing in heating installation.

ATTENTION: It is not allowed to install any valve on the ascent or downcomer tubes and water circulating tube. Tubes and collect water bin should be protected against water freeze.

SAS AGRO-ECO type boilers may work with gravitational or forced water circulation. **Differential valve** should be mounted on supply / return tube if circulating pump is used in installation. In case of electric power cut-off or pump damage valve will open automatically and circulation will work in gravitational system.

ATTENTION: It is recommended to connect boiler to heating installation equipped with three- or four - way valve. The advantage of proposed boiler connection method is boiler protection against low temperature corrosion. Thanks to that boiler life – time will be longer.

In case of not observing manufacturer recommendations regarding maintaining of defined heating water temperature ranges (defined in Table TECHNICAL AND OPERATION PARAMETERS, mainly long-lasting water low temperature keeping below 55°C) boiler must be connected to heating installation equipped with three- or four – way valve which protects boiler against „low temperature corrosion”.



6.5. ELECTRICAL SYSTEM CONNECTING

Boiler – room should be equipped with 230V / 50Hz electrical system realized according to requirements of currently valid detailed regulations of destination country. Electrical system must be terminated with wall outlet with ground contact. Defective electrical system may cause controller damage and user electric shock. Extension cords are not allowed to use.

Controller and other actuators are supplied with 230 V voltage and because of that all connections can be realized only by authorized person (**authorized electrician**). Power cords for other devices supplying must be kept away from boiler elements, which becomes hot during boiler utilization (cover of upper cleanout opening, smoke conduit, door).

7. GUIDELINES FOR OPERATION AND MAINTENANCE

7.1. FILLING WITH WATER

Boiler and installation filling with water should take place by boiler blowdown connector. **In order to remove air from installation filling must be conducted very slowly.** Water outflow from overflow pipe means complete installation filling.

It is recommended to loose screw joint on boiler and installation connection place (on the hot water connector pipe) when filling with water. On the water outflow moment screw joint should be tightened.

ATTENTION: Filling with water during boiler operation, mainly when boiler is very hot is inadmissible and forbidden. It can cause boiler damage or crack!

After heating season water shouldn't be drained from installation and boiler. If required water is drained after cooling via blowdown connector to sink or floor drain.

7.2. BOILER FIRE-UP AND OPERATION

Before fuel fire – up it is mandatory to check installation filling with water. Water can't be frozen. It must be checked also if there is no water leakage on boiler or screw joints. Before first boiler start – up chimney must be burned.

**Person who servicing boiler must be aware about that some boilers surfaces are hot and before touching it is mandatory to wear protective gloves!
Safety goggles also should be used.**

7.2.1. BOILER FIRE-UP AND OPERATION IN AUTOMATIC MODE

Electrical fire - up

Thanks to build – in incandescent spiral burner fire-up in SAS AGRO-ECO type boiler is realized automatically. In order to run boiler (furnace fire-up) it is required only to activate “IGNITION” function in controller menu.

In fire-up mode controller operates fuel feeder – fuel is delivered at fire grate, in the same time electrical ignition is started. During fire-up controller verifies process by constant measurement of waste gases temperature. When flame appears in furnace electrical heater is off and boiler is switched to operation mode. Volume of air delivered by downcast ventilator and fuel quantity delivered to furnace is adjusted automatically according to defined, optimal parameters specified for particular fuel type (service parameters).

After single fire-up boiler operates with no service and combustion process go on continuously. Further boiler service requiring only storage bin refilling and ash removing from ashtray. During fuel loading to charging hopper special attention must be pay – bigger pieces of some foreign matter or stones can't be present on fuel because they can cause feeder blocking!

Controller settings should be defined depending on temperature outside of building and quality of used fuel. For more information please read controller service manual delivered with this documentation (chapter “Boiler operation parameters programming”).

Depending on weather conditions regulation of specific flame output and boiler thermal power should be changed by regulation of temperature of water out flowing from boiler (if three – or four – way valve is used, then regulation damper position should be change).

Controller operates also circulating pump of central heating system (if heating installation is equipped with circulating pump).

It is not recommended to open any door during boiler operation because it can cause waste gases withdrawal to charging hopper. When fire-up, smoking to boiler-room or boiler wetting may appear. After boiler and chimney duct heat up mentioned above effects should abate.

In central heating system demand for warmth is changing together with external conditions, it means with daytime and ambient temperature. Value of temperature of water out flowing from boiler depends also on building thermal characteristic – mainly materials used for construction and insulation material characteristics are important.

Manual fire-up

If burner fire-up using incandescent spiral fails (error message: „UNSUCCESSFUL ATTEMPT TO START FIRE (IGNITION FAILURE)) there is a possibility of spiral damage. In this situation following points must be checked: 1° Does charging hopper is filled with fuel? Some unwanted object does not block does gear? 2° Does furnace is not filled with excessive quantity of ash, which preclude fuel ignition from heater? If heater is damaged, burner must be run in manual fire-up mode (→) :

1. Furnace must be cleaned from heat and soot, burner controller must be off.
2. In manual operation mode fuel must be loaded to fire grate
3. Fuel must be sprinkled with other flammable fuel, wait till percolate
4. Fire-up
5. Run the controller and select “IGNITION” function

Person who servicing boiler must be aware about that some boilers surfaces are hot and before touching it is mandatory to wear protective gloves!



7.2.2. BOILER FIRE-UP AND OPERATION IN EMERGENCY MODE

Before fire-up, fuel-loading door (pos 3) must be opened, cleanout door (pos 2) and ash box door (pos 7) should be fully closed. Substitute fire grate (pos 22) should be placed inside of furnace chamber.

In order to protect against waste gases withdrawal to charging hopper in emergency mode (using substitute fire grate) it is recommended to partially fill the storage bin (pos 13). This will also protect against smoking from charging hopper.

Fire-up should take place slowly, initially squeezed sheets of paper and wood should be used. Thin hard coal portion should be added later. When hard coal portion kindle – up, a little bit bigger hard coal portion should be added. When this portion is kindled, after closing the double door furnace chamber can be filled with fuel via fuel loading door. Next air dosing flap in double door position should be set using adjusting screw in order to reach required caloric effect and required temperature.

In case of fire in boiler extinguish, furnace must be cleaned, boiler ducts must be ventilate and fire-up must be started again.

During normal operation in “traditional combusting” mode combusting process consist in periodical refueling in furnace chamber. Single refueling in case of emergency mode is enough for few hours of boiler operation, depending on reached boiler power.

7.3. BOILER CLEANING

In order to ensure economical fuel consumption and reach boiler thermal power and efficiency it is mandatory to keep clean boiler combustion chamber and convectional ducts.

In combustion chamber special attention must be pay for periodical cleaning of micro – gaps in automatic furnace panel.

Convectional ducts, on which volatile ashes creating layers must be cleaned systematically every 3 – 7 days. This is very important in case of boiler operation in “traditional combusting” mode. Boiler is equipped with special tools for this purpose.

Front cleanout door (pos 2) and fuel loading door (pos 3) makes possible to clean convectional ducts. Additionally, air chamber located on the boiler rear side must be also



cleaned periodically because ash flowing from automatic furnace panel accumulates in this area. Lateral cleanout hole (pos 7) is destined for this cleaning.

Cleaning of chimney duct is also critical for proper boiler operation.

7.4. OPERATION ENDING

After heating season, or in case of other scheduled boiler stopping, loaded fuel portion should be burnt. After fire dump all residues of combusted fuel must be removed, boiler should be cleaned and maintenance activities should be performed. Internal furnace chamber bafflers and all movable components should be lubricated with oil. Mechanism that is used for fuel delivering to furnace chamber must be protected during boiler non-operating time (horizontal sideways lubrication).

After heating season water shouldn't be emptied from installation and boiler. In case of emergency boiler damping hot fuel must be removed to tin boxes and carry out outside boiler-room. It is also possible to spill incandescent fuel with sand.

ATTENTION: Fuel extinguishing with water in boiler-room is forbidden!

8. SAFE OPERATION CONDITIONS

In order to ensure safe boiler operation following rules must be observed:

- boiler and installation must be maintained in good technical condition. Special attention must be pay to central heating installation leakproofness and door and cleanout holes closings leakproofness,.
- keep boiler-room clean, do not store any objects not related with boiler servicing,
- on the wintertime do not switch off heating. If boiler is not used, water can froze in installation or in part of installation, freeze-up of overflow safety outlet pipe is very dangerous; it can cause boiler destroying,



- usage of petrol, kerosene, dissolvent, or similar substances for boiler fire – up is forbidden because it may cause explosion or user injury,
- in case of installation failure and lack of water in boiler, water can't be refilled when boiler is hot because it can cause boiler failure,
- all boiler defects should be repaired immediately.

Boiler must be cleaned regularly from soot and soot substances – each sediment on the convectional ducts walls disturbing heat absorption from heat exchanger – boiler efficiency is lower and fuel consumption is higher.

9. TROUBLESHOOTING

PROBLEM	REASON / SYMPTOM	SOLUTION
Low boiler calorific effect	flues impurity	clean – up flues via cleanout hole door
	no fresh air inflow to boiler-room	check supply ventilation condition in boiler-room, improve airflow
	inadequate fuel applied	apply fuel with proper quality (please read “Fuel” chapter).
	wrongly calculated boiler power in relation to building surface	
	incorrect design and realization of central heating system	
	incorrect operation of controller, ventilator or feeder	define new controller settings according to weather conditions and kind of fuel, mainly feeder operation time and fuel delivery pauses should be changed if controller doesn't work correctly, please refer to controller user manual
Smoking	insufficient chimney draught (if chimney draught is too weak smoking from boiler may appear, mainly when boiler starts-up)	please check chimney operation correctness (refer to Table 2 with manufacturer recommendations), check also if chimney is not ending below highest roof ridge.
	flues impurity	clean-up boiler via cleanout hole door

Smoking	wear of stuffing used for door and cleanout holes	exchange stuffing used for door and cleanout holes (this material is subject for regular exchange)
	incorrect connection of boiler and chimney	check precision of connection between boiler and chimney
	very low atmospheric pressure	
	smoke emanating under charging hopper when fuel is combusted in emergency mode	In order to protect against waste gases withdrawal to charging hopper it is recommended to partially fill storage bin
Sudden temperature and pressure raising	installation valves closing	open valves
	collect water bin freeze-up	warm – up the collect water bin
Fire extinguish in furnace	feeder mechanism locking	switch-off controller from mains, remove fuel from charging hopper, remove object (e.g. lump), which is the reason of mechanism locking. Check feeder operation correctness in manual mode. If problem persists, please contact with service representative.
	wet fuel suspending in charging hopper	empty charging hopper, provide dried fuel
	incorrect fuel quality	apply fuel according to recommendations included in “Fuel” chapter
Water outflow from boiler	so called “boiler wetting” is natural effect caused by temperatures difference in boiler	when boiler start-up and after every boiler banking boiler must be “warmed” – temperature 70°C must be reached and kept for few hours.

10. PROTECTIONS

In order to ensure failure-free and safe operation controller is equipped with various protections. Sound alarm is activated and error message is displayed on display (depending on controller version) in case of incorrect state detection.

THERMIC PROTECTION Boiler controller is equipped with safety temperature limiter, which protects against boiler overheating (water in installation boiling) in case of controller failure. Safety temperature limiter is a mechanical method of protection and is build as a bimetallic sensor, located near to boiler water temperature sensor. If temperature 90°C is



exceeded, this protection cut off the downcast ventilator and fuel feeder power supply. Pump remains operating.

TEMPERATURE PROTECTION In case of thermic protection failure, controller is equipped with additional temperature protection (electronics circuit). If temperature 95°C is exceeded, this protection cut off the downcast ventilator and fuel feeder power supply.

STORAGE BIN PROTECTION Controller is equipped with additional protection against flame back to storage bin (charging hoper). Temperature sensor, which measure temperature near to storage bin, is connected to controller. In case of sudden temperature raising (flame back) alarm is activated and fuel is push out to combustion chamber.

SAFETY VALVE Boiler is equipped with safety valve which is additional protection against pressure raising in case of water freeze-up in some part of installation, particularly in collect water bin.

11. DELIVERY CONDITIONS

Boilers for sales are delivered as assembled product, including tools kit for service and technical documentation.

Before boiler connecting to central heating system it is mandatory to check if all boiler elements are fully working and all required elements are included.

ATTENTION: Boilers must be transported in vertical position!

12. BOILER UTILIZATION

In order to utilize boiler, device must be delivered to authorize institution, according to requirements of currently valid detailed regulations of destination country.

13. TERMS OF WARRANTY

1. Manufacturer grants warranty for proper functioning of the heating boiler SAS AGRO-ECO, what is confirmed with the stamp of factory.
2. Manufacturer grants warranty for the period covering the boiler installed and operated according to all terms and recommendations included to Technical -Start-Up Documentation (TSD).
3. A buyer gets together with terms of warranty hereby Technical-Start-Up-Documentation (TSD), which is laid down rules for the proper operation and safe exploitation of the heating boiler. Hereby documentation (TSD) must be reading careful and it is obligatory.
4. Warranty terms are binding from the date of the purchase for the period of:
 - a. 5 years * for efficient functioning of the boiler,
 - b. 2 years on electronics and automation components mounted on the boiler and produced by other manufacturers:
 - controller
 - blowing fan
 - safety valve
 - gear motor in feeder AGRO-ECO
 - engine in feeder AGRO-ECO
 - ceramic heater
 - automatic fuel delivery system
5. Warranty does not cover consumable items:
 - sealant (rope)
 - capacitor
 - sensors
6. Manufacturer is obligated to carry out the charge free repair under warranty in time period of 14 days starting from the date of application (done by user).
7. Boiler's repair, the construction or insulation alterations made by user or other third parties – will cause the warranty to be invalid.
8. Application of reclamation should be addressed at manufacturer.
9. Boiler replacement realized by manufacturer is only possible based on expert opinion, that repair is not workable.
10. If the advertiser does not allow double-warranty repairs, despite the willingness of the guarantor to comply with it, is deemed to have resigned from the advertiser claims contained in the application of reclamations.

* for boilers with nominal power rated ≥ 48 kW guarantee period is equal 24 months.



11. In case of unfounded service summon, the customer shall pay travelling and work costs. Before you call service, please familiarize yourself with the chapter "States of improper boiler's functioning". We always offer help by telephone.

12. Warranty card makes up the only ground for charge free repair.

NOTE: Manufacturer reserves the right to introduce changes in the construction of the product for modernization purpose. Such changes may not be reflected in hereby documentation, however basic, described properties of the product shall be maintained

If you have any remarks or inquires regarding SAS boilers utilize, please feel free to contact us:

ZAKŁAD METALOWO-KOTLARSKI



Owczary, ul. Przemysłowa 3
28-100 Busko - Zdrój

Tel.: +4841/378 46 19 Fax: +4841/370 83 10

[http:// www.sas.busko.pl](http://www.sas.busko.pl)

e-mail :biuro@sas.busko.pl



SERVICE REPAIRS



WARRANTY CERTIFICATE

Number

According to provided conditions we provide warranty for 60(24*) months for low – temperature boiler of SAS AGRO-ECO type installed and operated according to Technical Documentation.

Boiler serial number -

Thermal power -

Heated surface -

Manufacturing year -

.....
Manufacturer signature and stamp

.....
Seller signature and stamp

.....
Sales date

* for boilers with nominal power rated ≥ 48 kW guarantee period is equal 24 months.