



SPARE PARTS EXPLODED VIEW  
GAS-WALL BOILER ATM. BURNER

Model

**CLAS B X**

R8203530-05 - 11/09/2019

CLAS B X

Gas-wall boiler atm. burner

1	3301133	CLAS B X 24 FF	08-2018	-
2	3301214	CLAS B X 28 FF	08-2018	-
Col	Reference	Model type	Begin	End

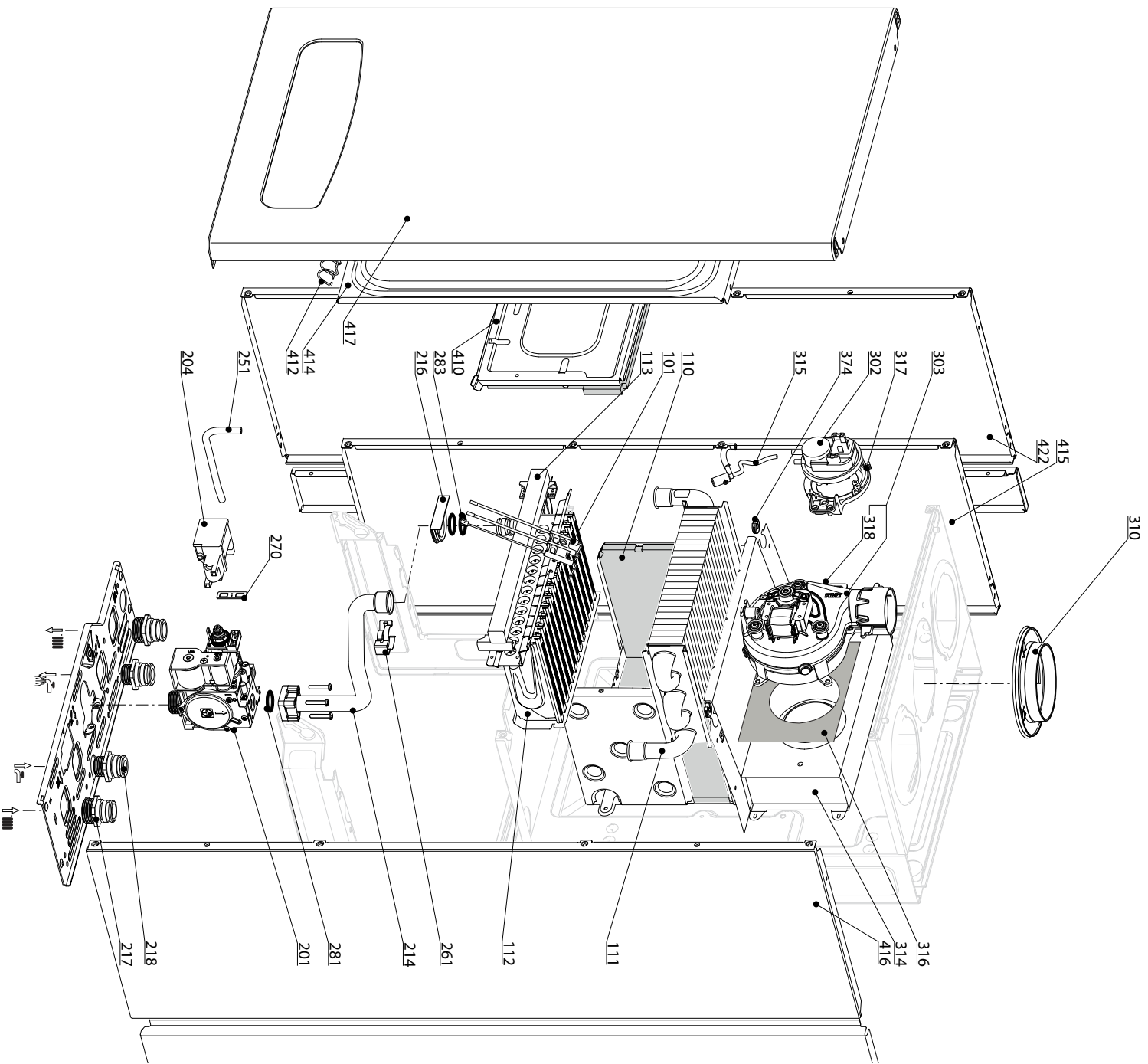



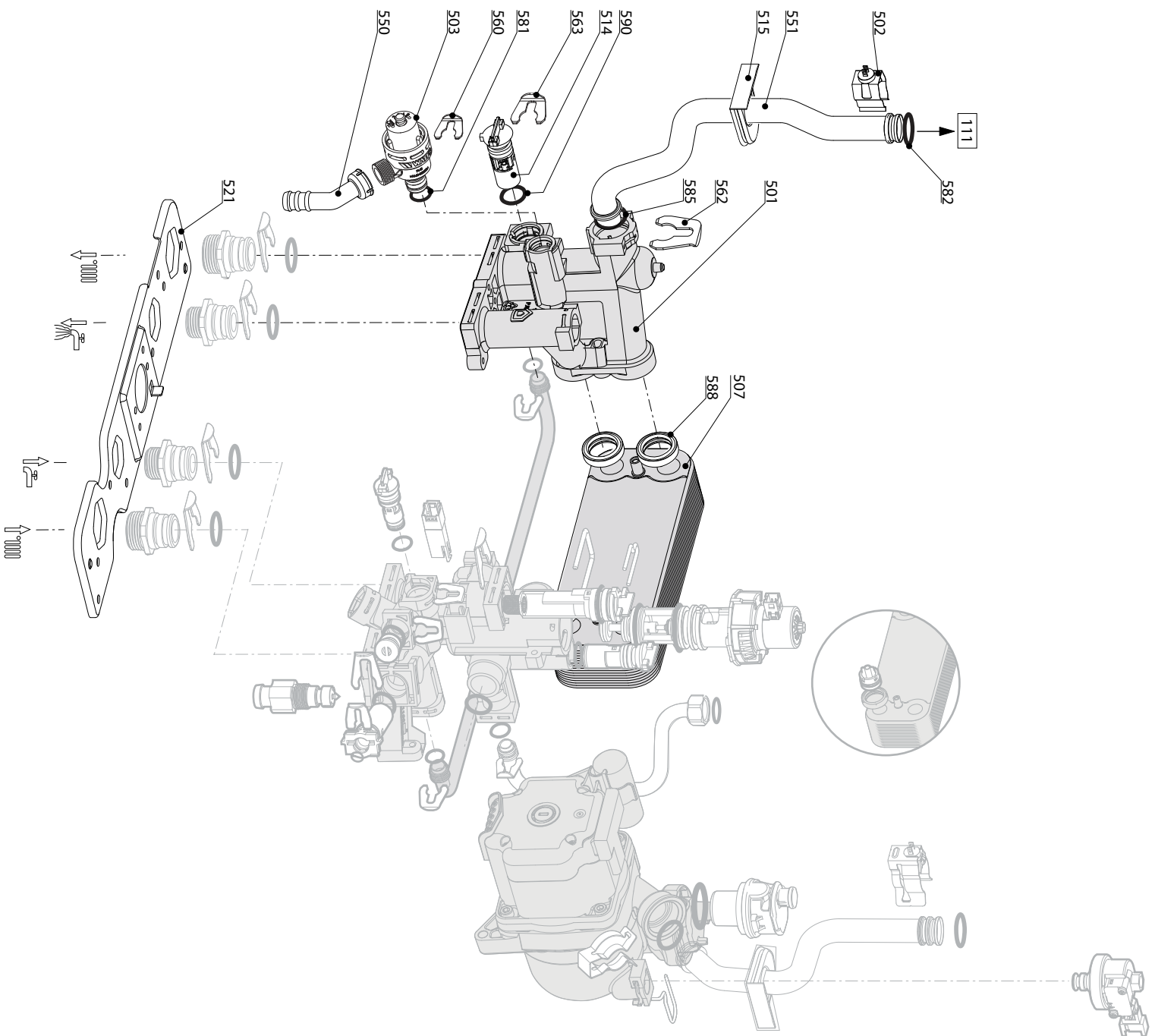



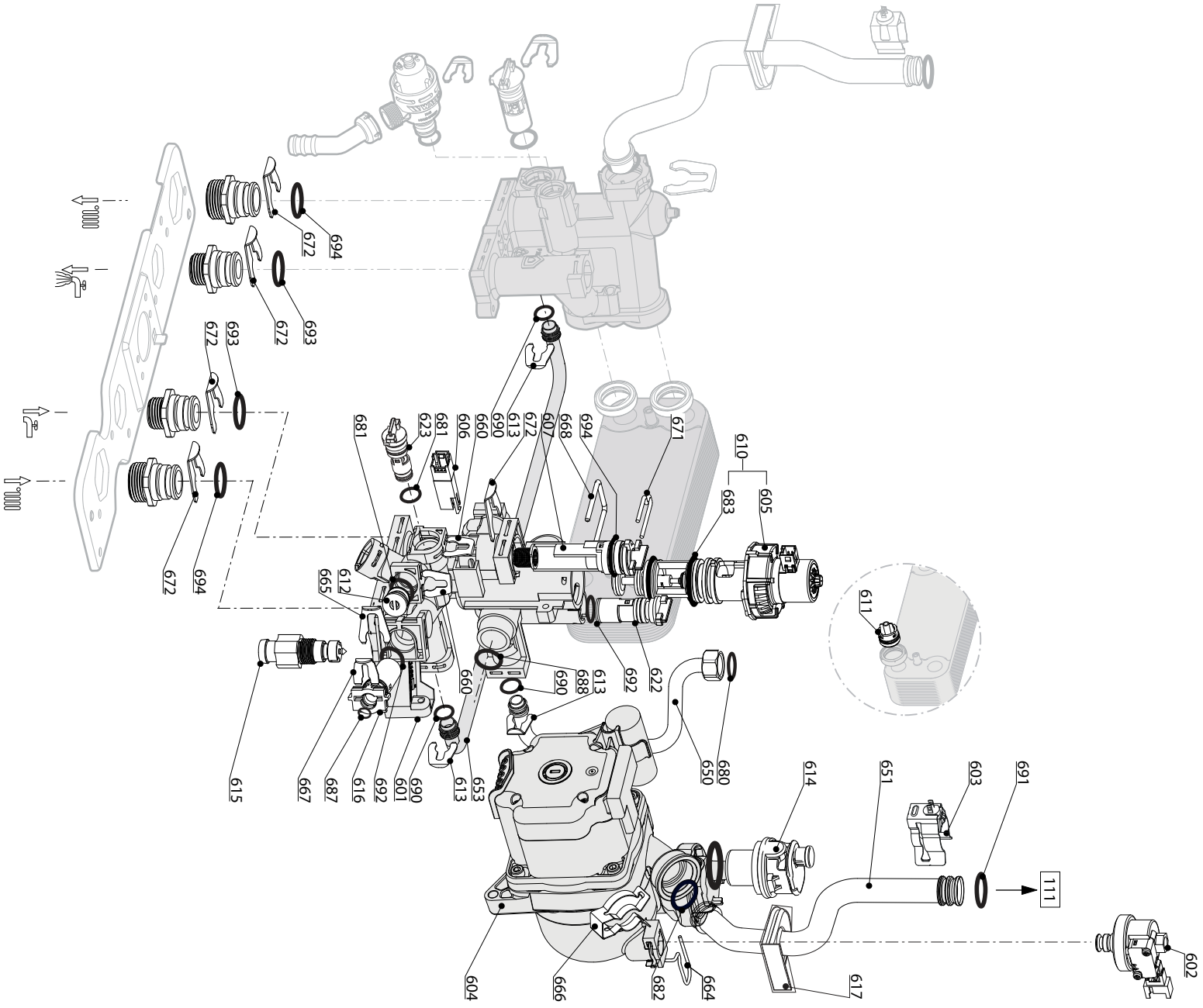



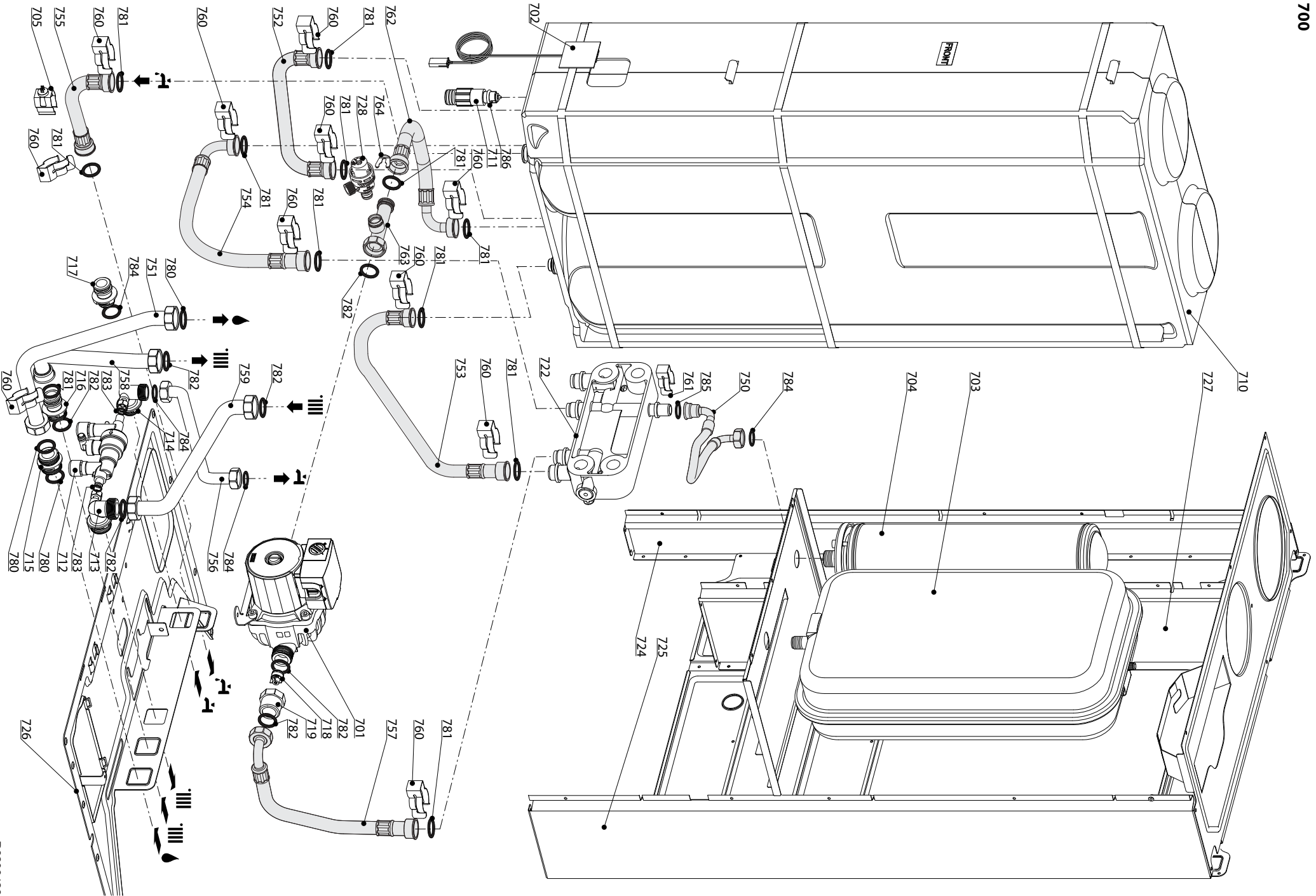





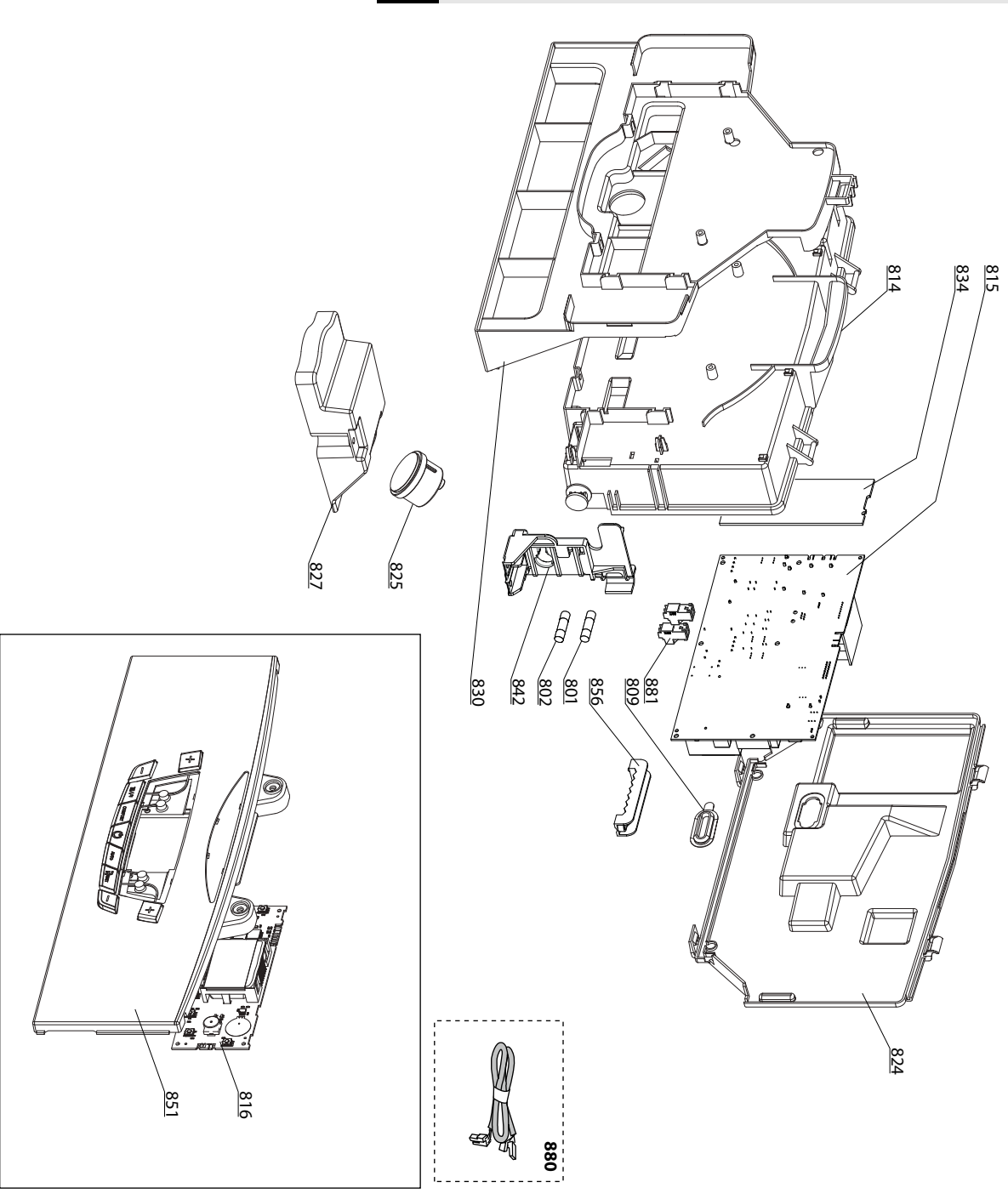

5000

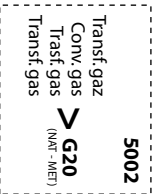
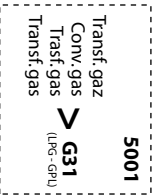



## LIST OF THE ABBREVIATIONS

HW .....	: Hot water.
CW .....	: Cold water.
C .....	: Ceramic resistance (normal heating).
Ca .....	: Ceramic resistance (accelerated heating)
TP .....	: Immersion heater.
1F .....	: With fittings.
2F .....	: Without fittings.
3F .....	: With fittings and another outlet connection.
AMI .....	: With mixing valve.
SMI .....	: Without mixing valve.
PUISS .....	: Power of th appliance.
PN .....	: Appliance with normal pression.
LP .....	: Appliance with low pression.
PV .....	: Appliance with variable power.
PF .....	: Appliance with fixed power.

## IDENTIFICATION PLATE

### SERIAL NUMBER

<b>10 Characters :</b>	04 05 125 011	Sequential number
		Manufacturing day
		Year of manufacture
<b>11 Characters :</b>	1 95 065004 - 31	Technical number of the appliance
Month of manufacture : from 1 to 9 → Jan. to Sep., O → Oct., N → Nov., D → Dec.		Sequential number
		Year of manufacture
<b>19 Characters :</b>	08 05 0013199 900640031	Product reference
Year of manufacture		Sequential number
Month of manufacture		
<b>20 Characters :</b>	3675007 XX 2 07 070 00315	Sequential number
Product reference		Manufacturing day
Millenium of manufacture		Year of manufacture
<b>21 Characters :</b>	3675007 XX 07 070 0000315	Sequential number
Product reference		Manufacturing day
Year of manufacture		