

ESBE SERIES CRA, CRB, CRC, CRD, CRS

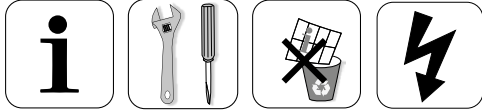

Series CRA110, CRA140, CRA150
Series CRB100
Series CRC110, CRC140
Series CRD100
Series CRS130

CE

LVD 2006/95/EC valid until April 19th 2016
LVD 2014/35/EU valid from April 20th 2016
EMC 2004/108/EC valid until April 19th 2016
EMC 2014/30/EU valid from April 20th 2016
RoHS 2011/65/EU

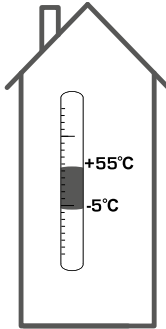

1

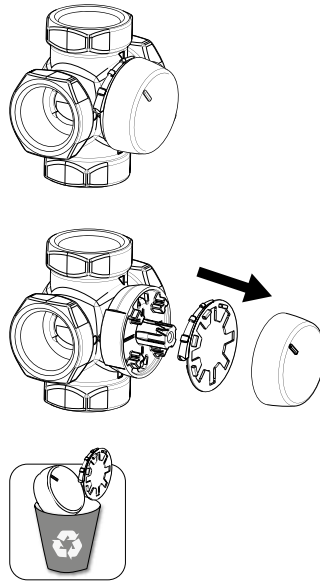

2

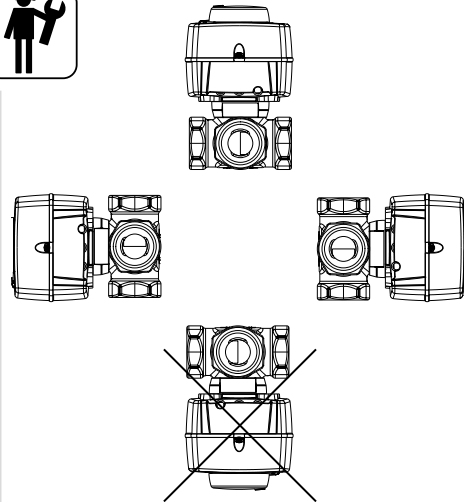

3



MG, G, F, H, HG, BIV, T, TM

	DN15-25	
	DN20-40	
	DN50	
	DN20-25	
	DN32-50	
	H: DN25	
	H: DN32-50	
	HG: DN25	
	DN20-22	
	DN25	
	T: DN20-32	
	TM: DN20	

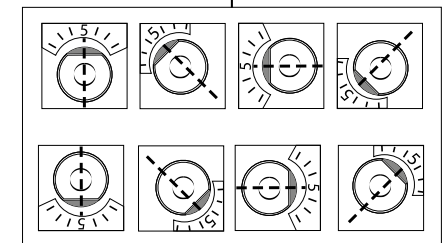
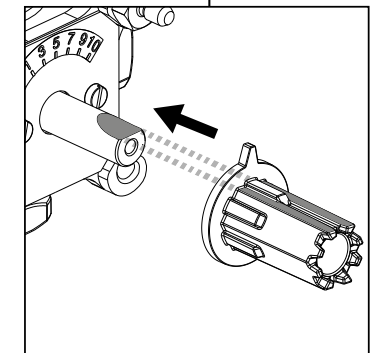
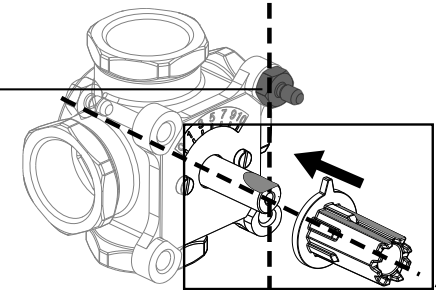

i



CRA110, CRA140, CRA150
CRB100
CRC110, CRC140
CRD100
CRS130



VRG, VRB, VRH

3MG, 4MG



3G, 4G

3F, 4F ≤ DN50

3HG, 4HG, 3H, 4H



BIV



T, TM

**VRG130, VRG140,
VRG230, VRG330
VRB140, VRH130**

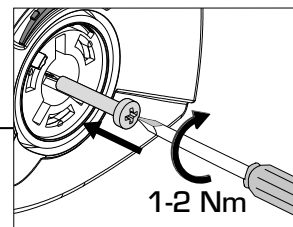
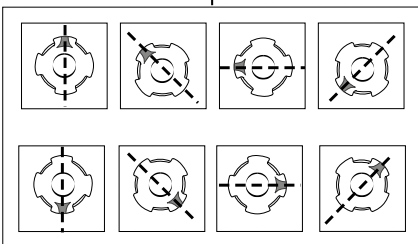
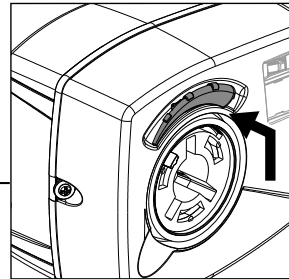
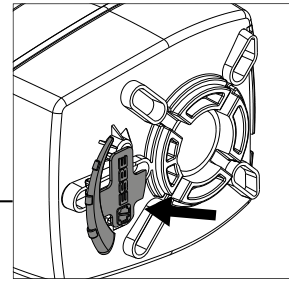
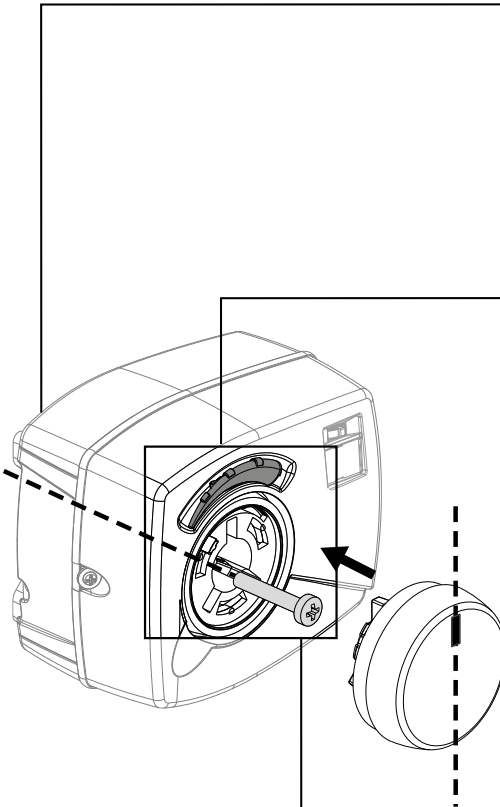
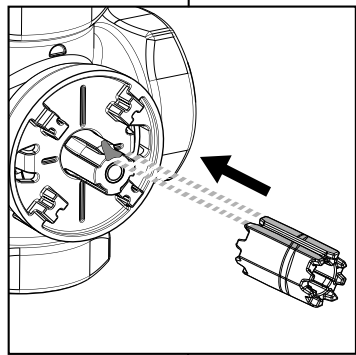
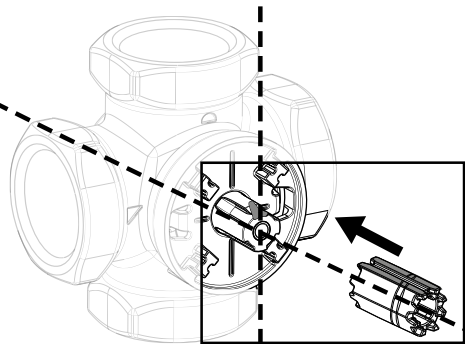

ESBE®
www.esbe.eu

Mtrl.nr: 98140403 • Ritn.nr: 8308 utg. D • Rev. 1512

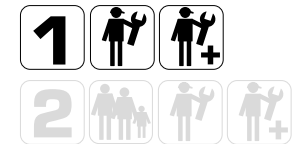

SERIES
**CRA110, CRA140, CRA150, CRB100,
CRC110, CRC140, CRD100, CRS130**

ESBE®

NO.1 IN HYDRONIC SYSTEM CONTROL

SERIES VRG130

a

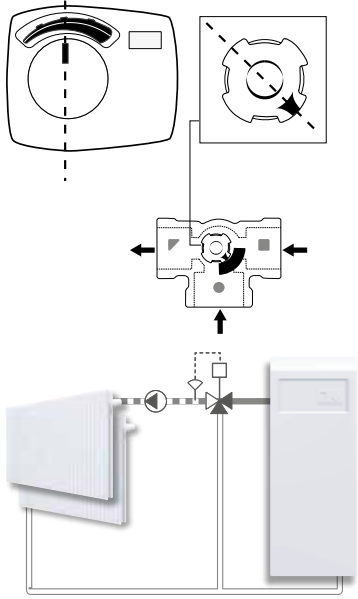

b

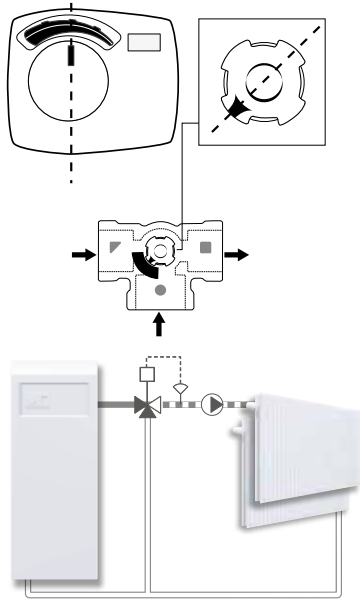

c

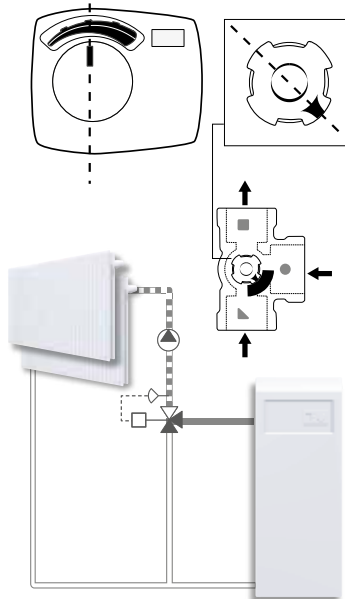

d

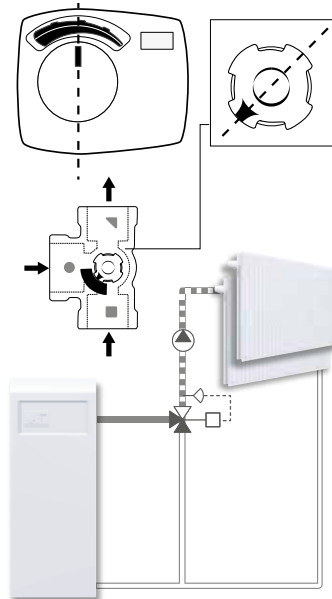

e

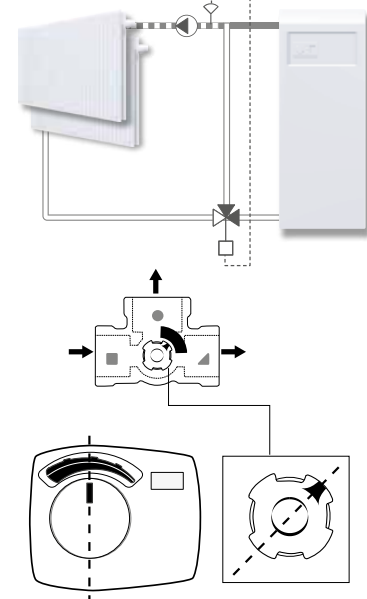

k

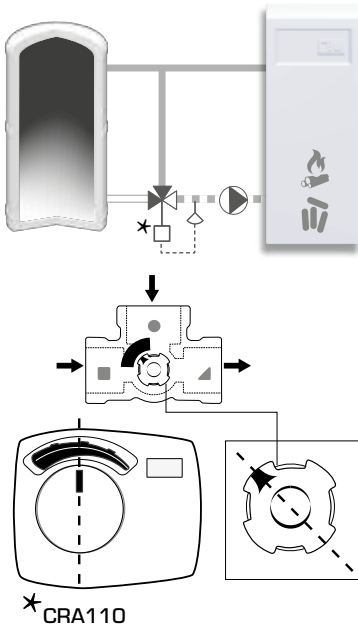

l

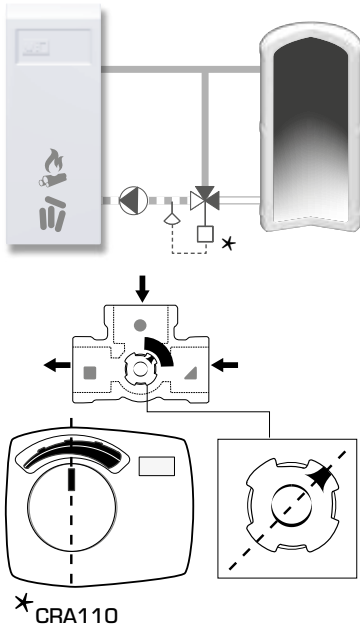

m

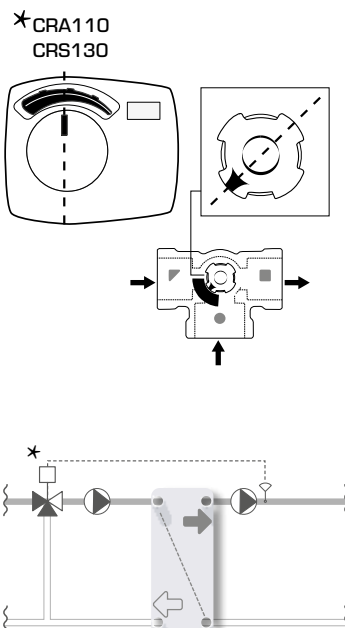

n

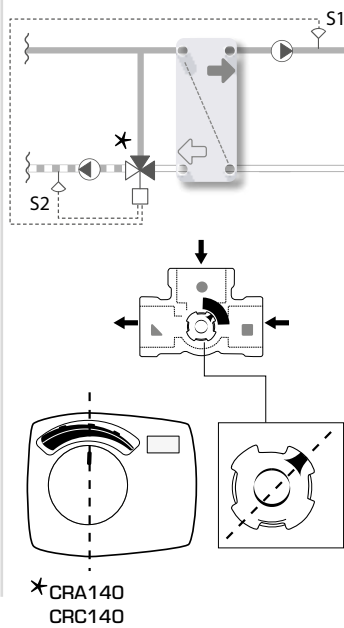

o

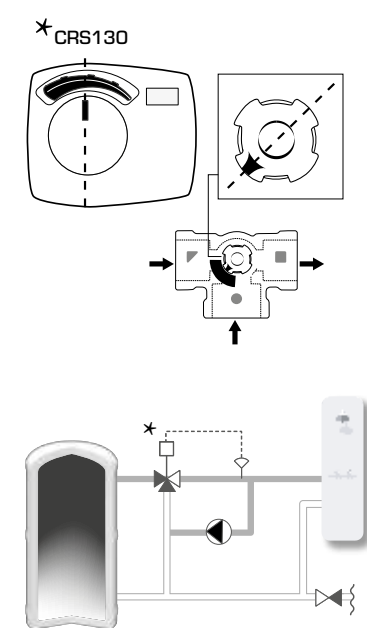

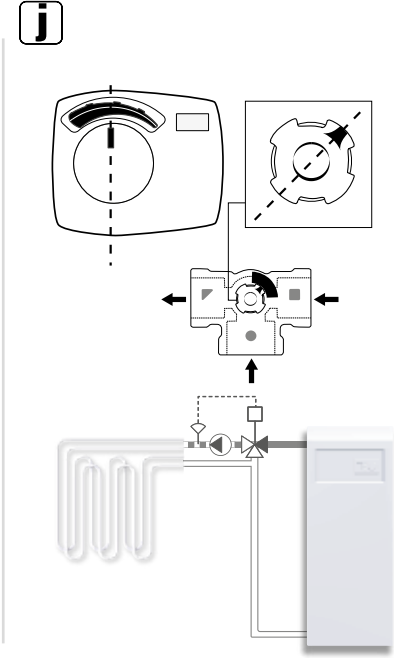
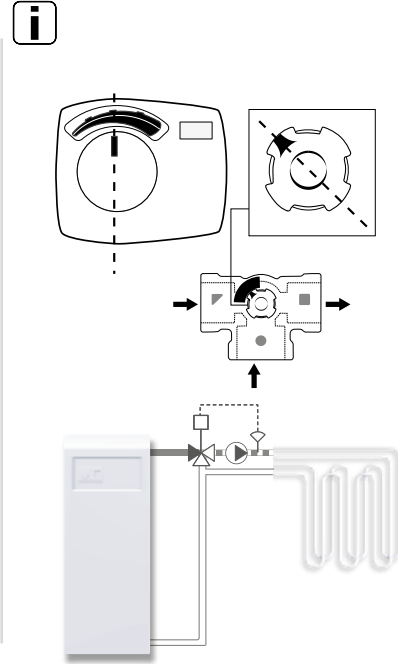
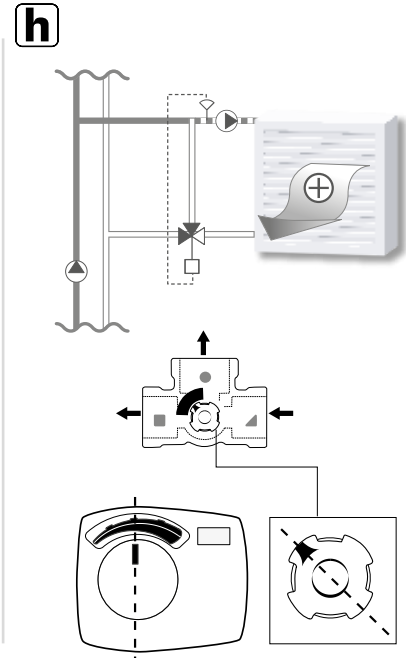
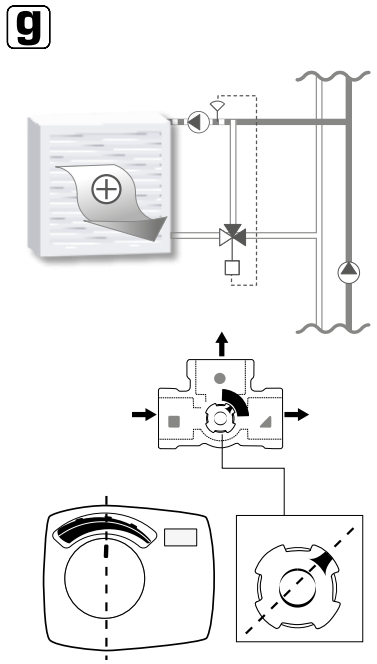
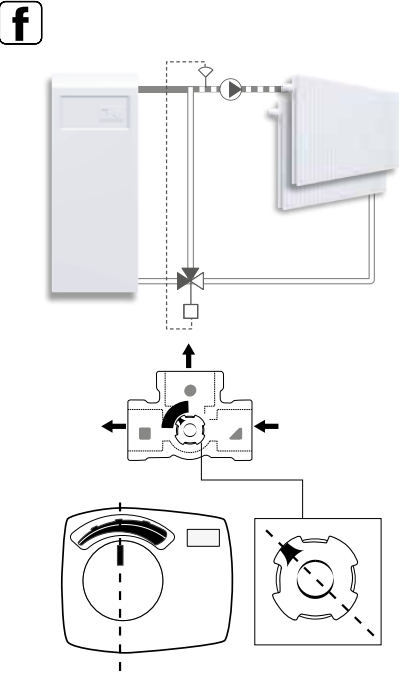

SERIES VRG140

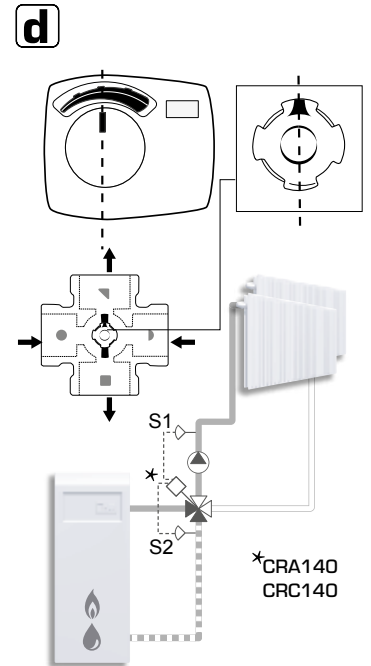
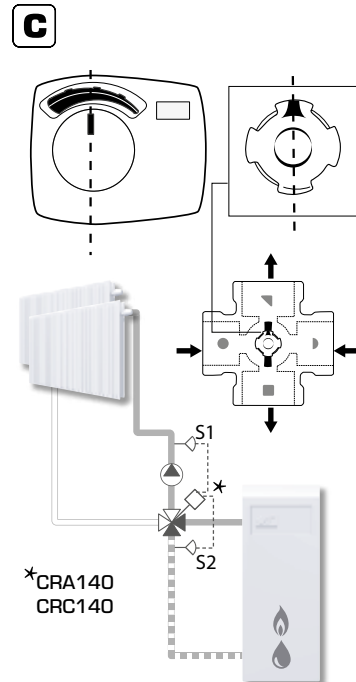
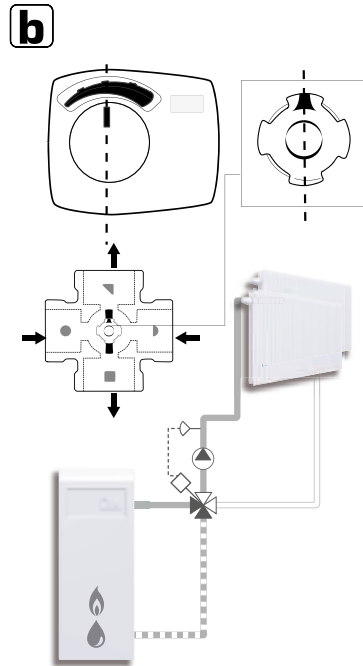
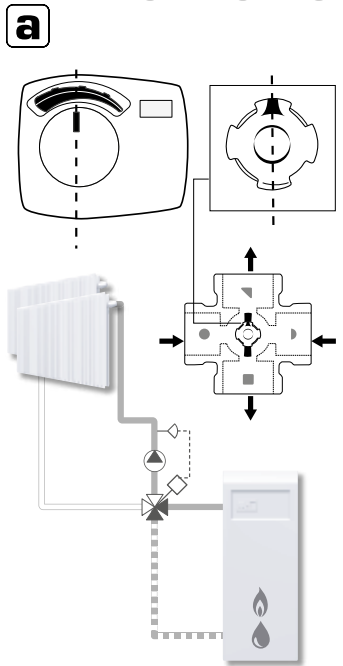

SERIES VRG230

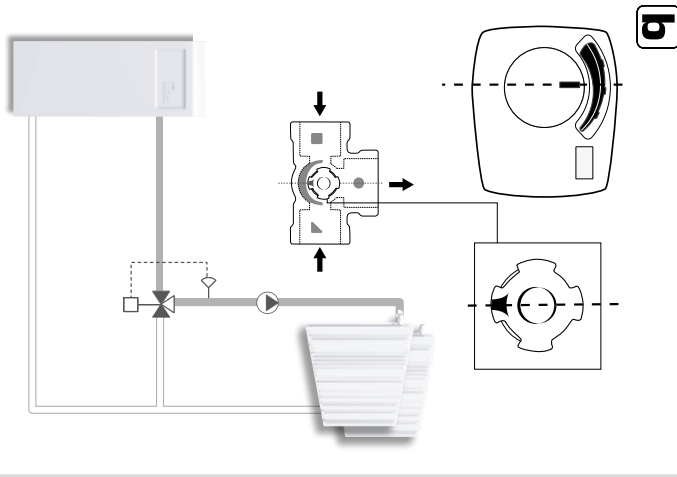
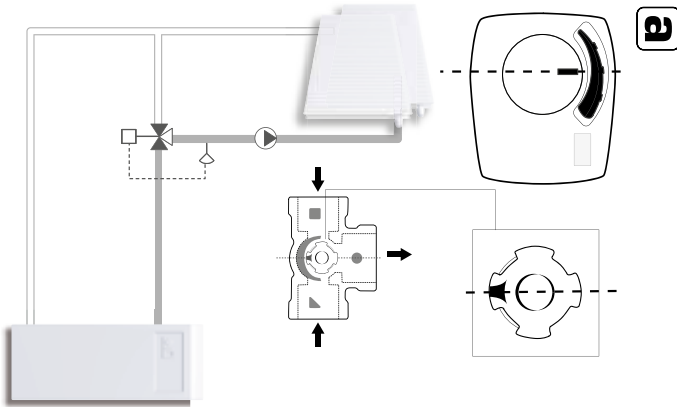

SERIES VRG330

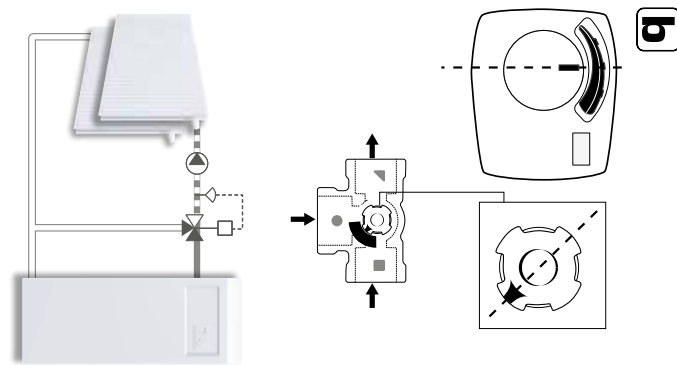
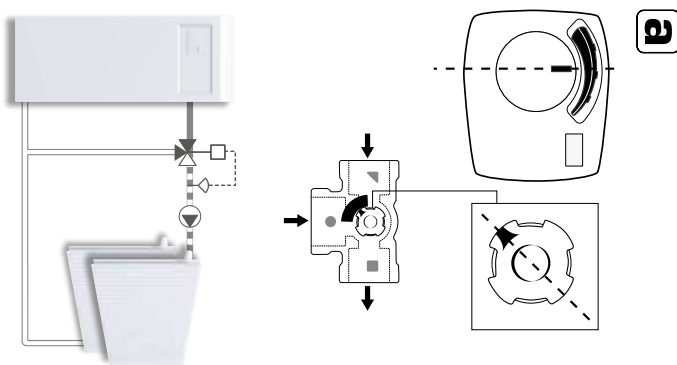

SERIES VRB140

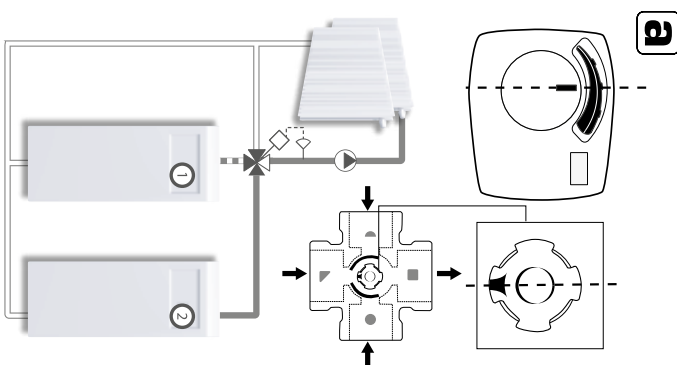

SERIES BIV

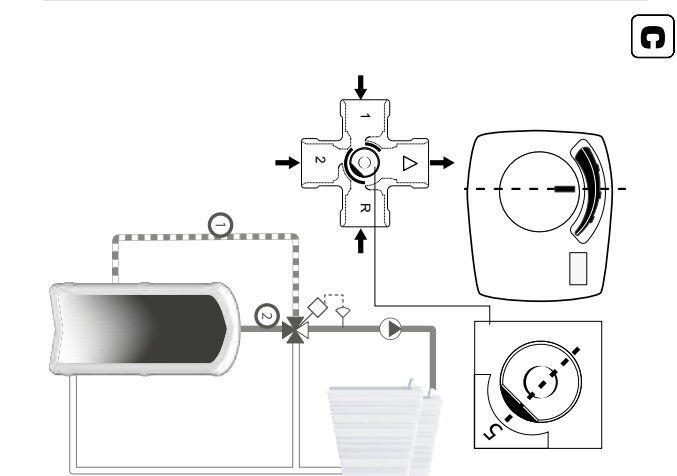
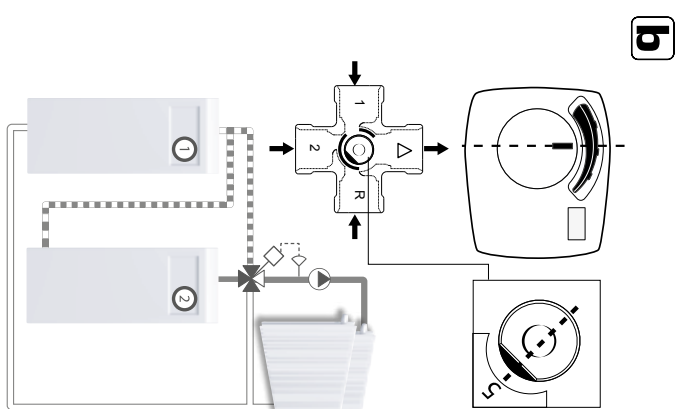
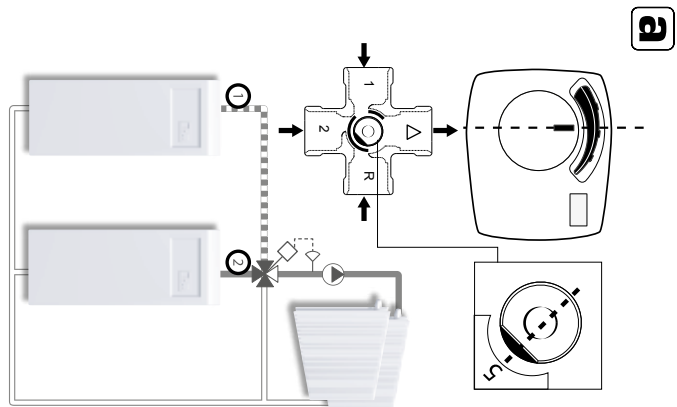

We would like to pinpoint to the existence of a German patent DE 19921256C5 affecting the usage of bivalent 4-way valves in liquid circulation heating systems. In this patent the usage of a 4-way bivalent valve in a type of heating system is protected, in which 2 different heating circuits are operated in parallel, where the return of the first circuit is utilized as heat source for the parallel second heat circuit. A typical application would be a primary heat circuit with a heat source and a parallel floor heating, where the floor heating in a regulated manner is heated through its heat source and the return from the primary heat circuit is utilized as alternative secondary heat source for the floor heating. Such a utilization of our bivalent 4-way valve without approval of the patent holder is forbidden. All other applications our product group VRB are without restrictions possible.

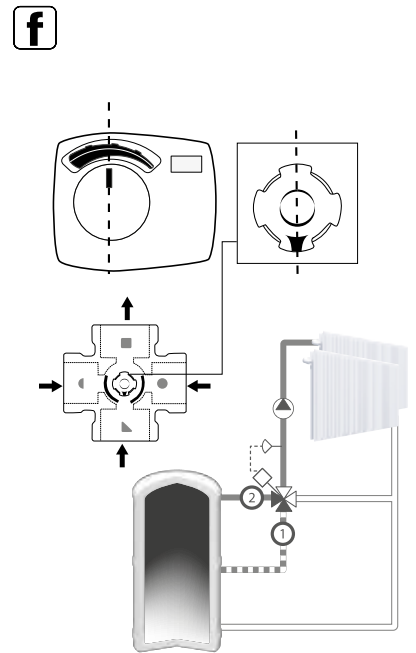
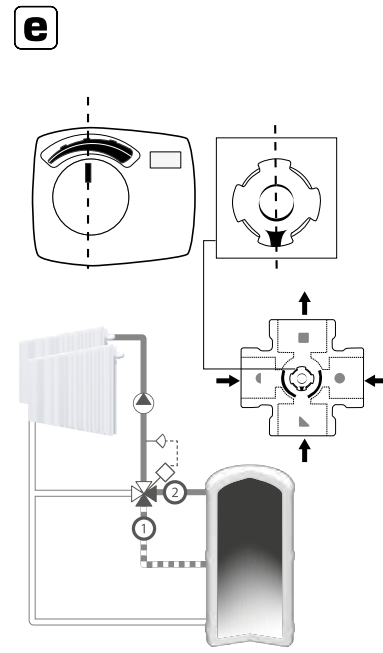
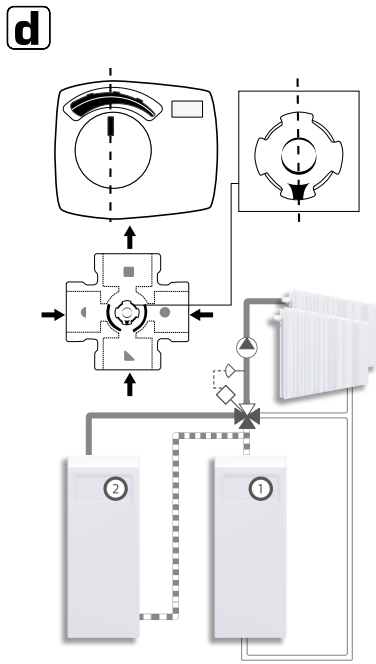
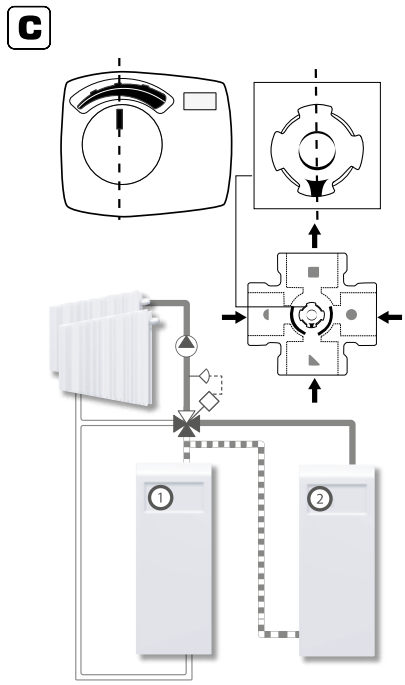
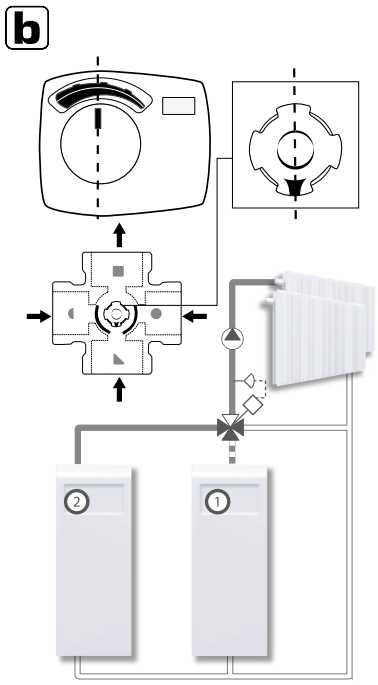

SERIES 4F, 4MG, 4G

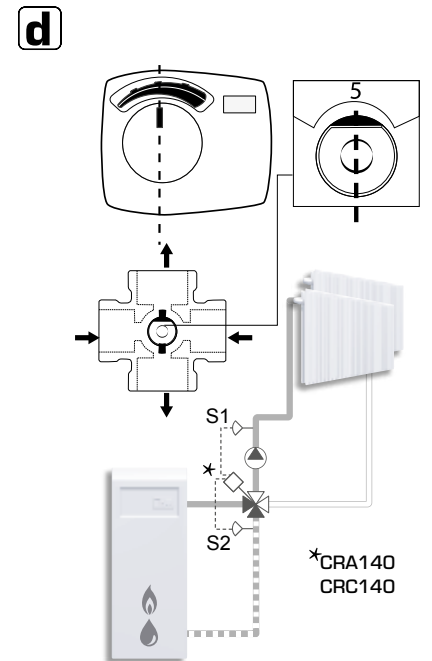
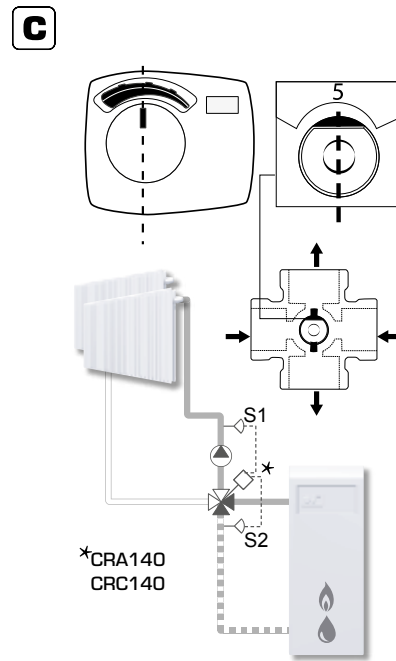
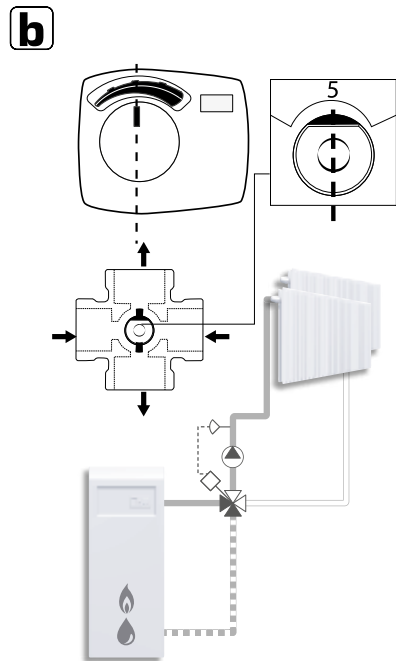
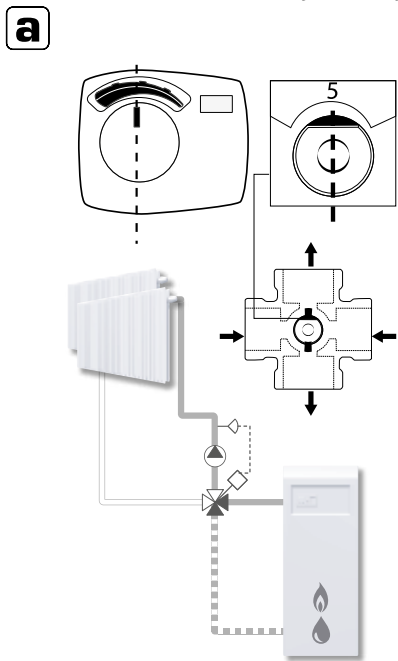

SERIES 3F, 3MG, 3G

a

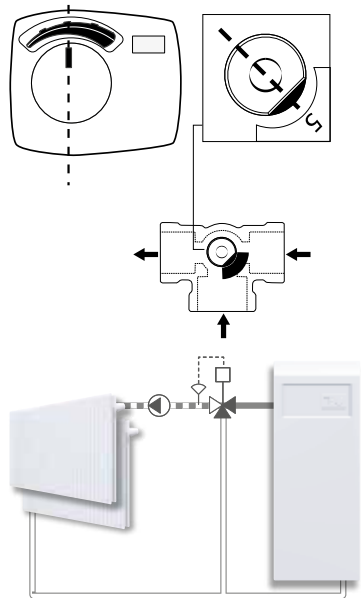

b

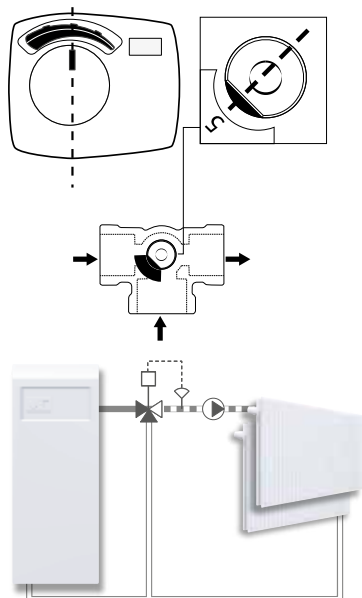

c

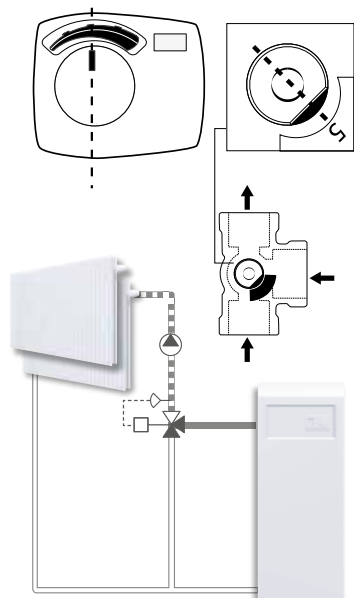

d

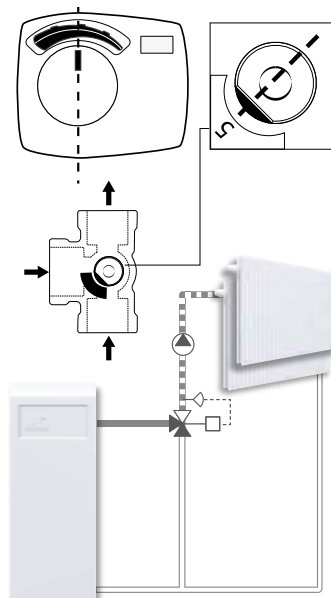

e

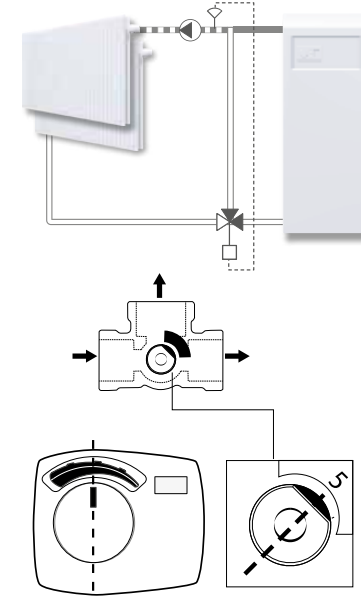

k

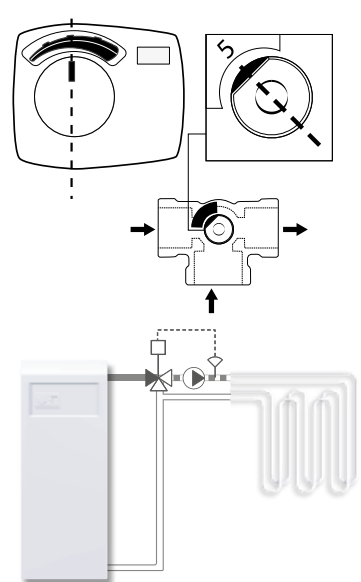

l

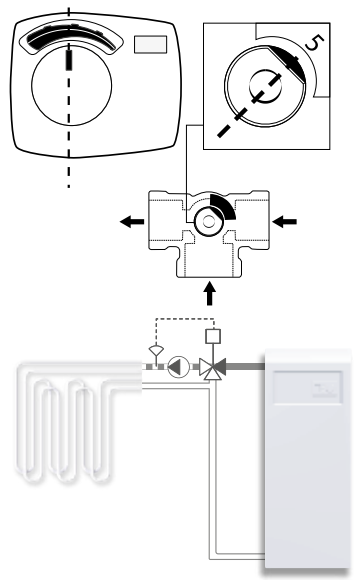

m

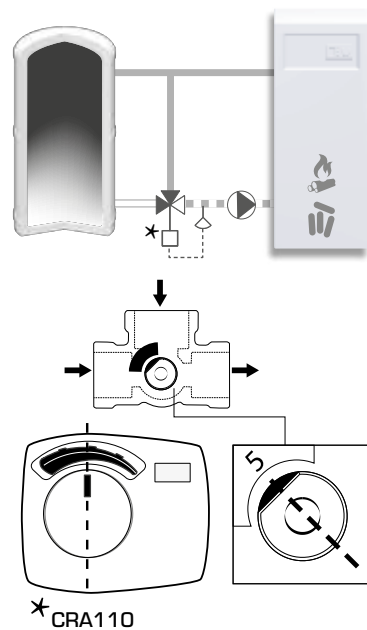

n

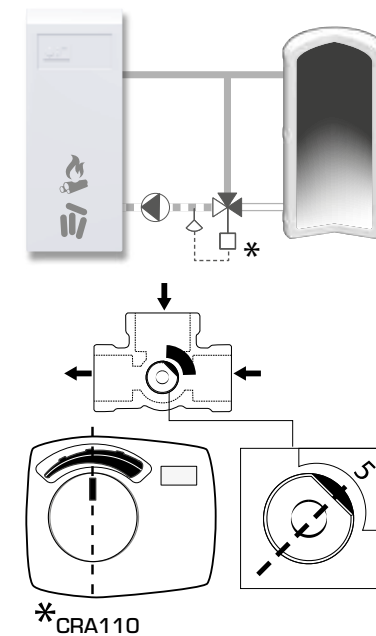

o

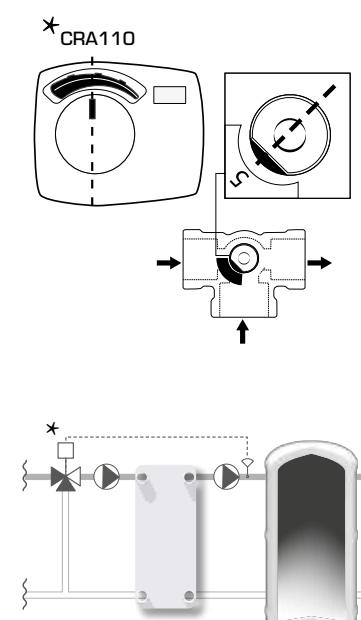

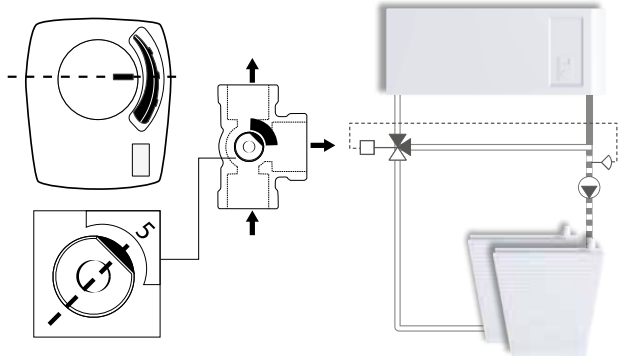
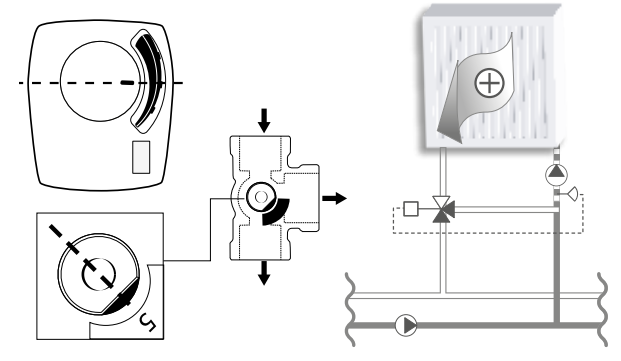
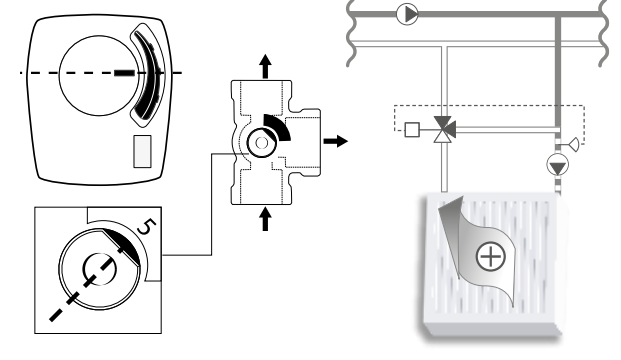
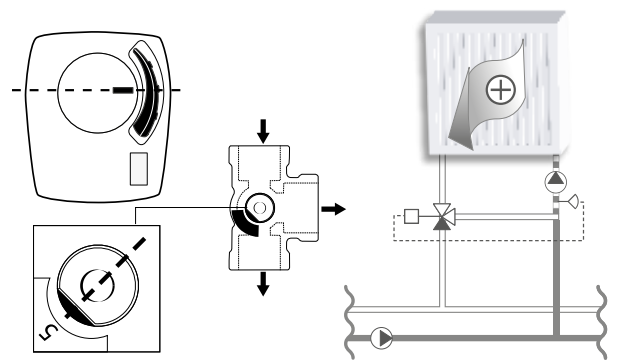
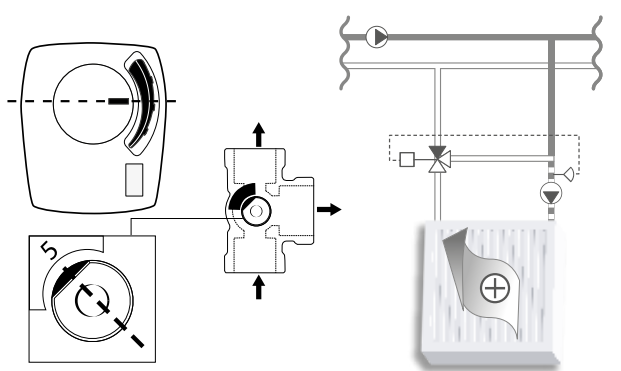
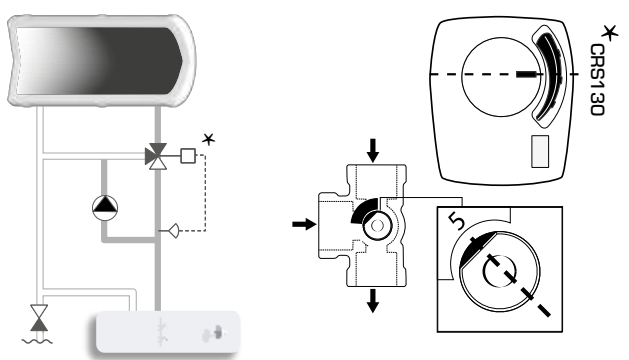
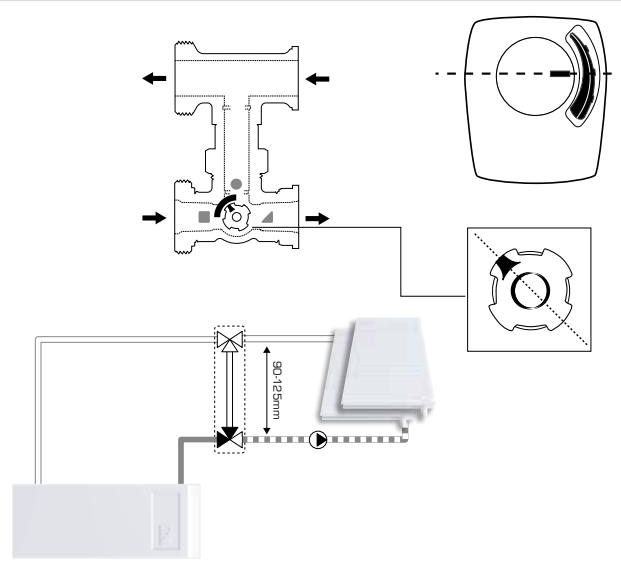
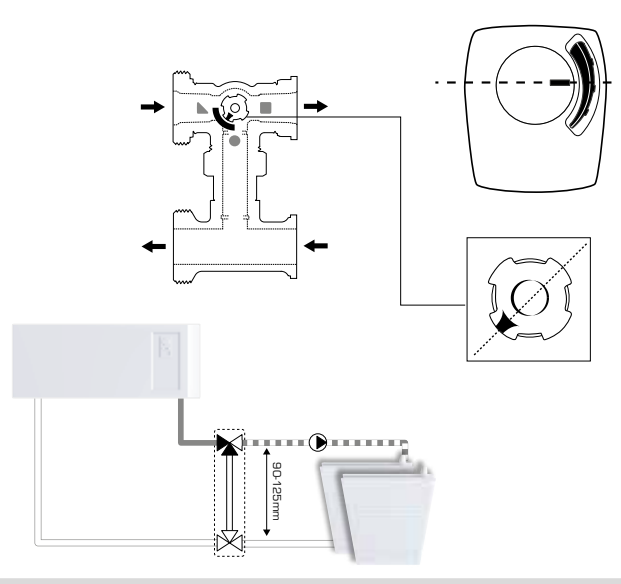
f**g****h****i****j****SERIES 3F, 3MG, 3G****p****SERIES 3F, 3MG, 3G****a****b***Piping Schematics are General Representations***i**